

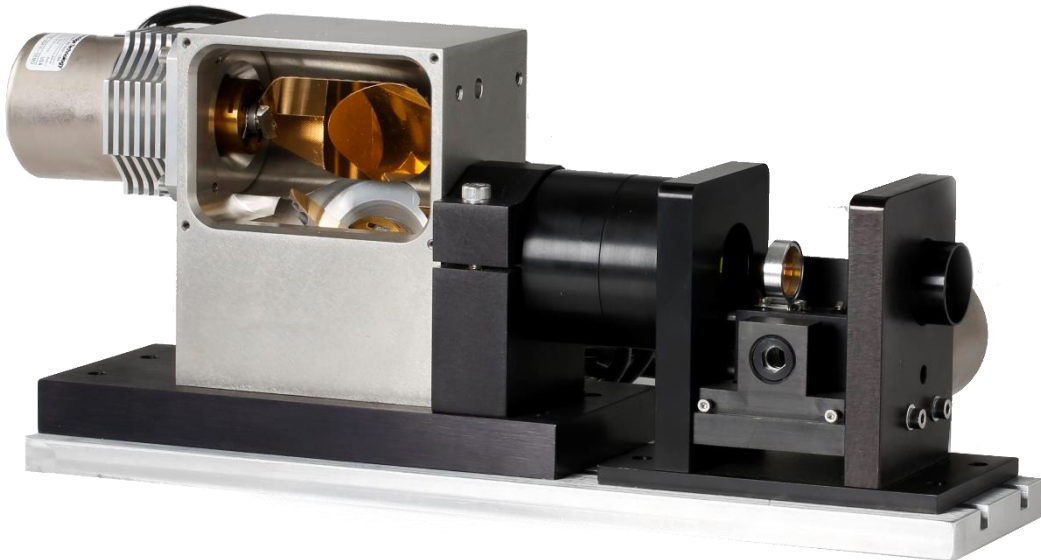

ScanMaster Designer 3D Extensions User Manual



Read carefully before using.
Retain for future reference.

Manufacturer

Novanta Corporation
125 Middlesex Turnpike
Bedford, MA 01730, USA
Phone: +1-781-266-5700
Email: Photonics@Novanta.com

Customer service

Before contacting us for assistance, please review appropriate sections in this manual that may answer your questions. After consulting the manual, please submit a request through our website: <https://novantaphotonics.com/technical-support-request-form-header/>

Americas, Asia Pacific

Novanta Headquarters
Bedford, USA
Phone: +1-781-266-5700
Email: Photonics@Novanta.com

China

Novanta Sales & Service Office
Shenzhen, China
Phone: +86-755-8280-5395
Suzhou, China
Phone: +86-512-6283-7080
Email: Photonics.China@Novanta.com

Europe, Middle East, Africa

Novanta Europe GmbH
Wackersdorf, Germany
Phone: +49-9431-7984-0
Milan, Italy
Phone: +39-039-793-710
Email: Photonics@Novanta.com

Japan

Novanta Service & Sales Office
Tokyo, Japan
Phone: +81-3-5753-2460
Email: Photonics.Japan@Novanta.com

Table of contents

1	How to use this user manual	12
1.1	Symbols and signal words	12
1.2	Notation conventions	13
1.3	Storage and replacement.....	14
1.4	Specifics and structure	14
1.5	Purpose	15
1.6	Target audience and qualification	15
1.7	Revision history	16

2	General safety instruction	17
2.1	Disambiguation of term 'laser unit'	17
2.2	Intended use	17
2.3	Reasonably foreseeable misuse.....	18
2.4	Radiation hazards.....	18
2.5	System safety	20
2.6	Modifications	20

3	Overview	21
3.1	What is laser marking?	21
3.2	Scan controller cards.....	21

4	Getting started	23
4.1	System requirements	23
4.2	Starting/exiting ScanMaster™ Designer	23
4.3	Workspace elements.....	25

4.4	Recommended workflow	25
<hr/>		
5	ScanMaster Designer interface – The Ribbon	28
5.1	Home	28
5.1.1	Standard.....	29
5.1.2	Edit	29
5.1.3	View	30
5.1.4	Mark.....	31
5.2	Project.....	31
5.2.1	Basic Elements	32
5.2.2	Marking Process.....	32
5.3	Modeling	32
5.3.1	Primitives	33
5.3.2	Transformations	33
5.3.3	Solid Operations	34
5.3.4	Boolean Operations.....	35
5.4	Engraving.....	35
5.4.1	View	35
5.4.2	Engraving Simulation	36
5.5	SurfaceMarking	36
5.5.1	View	37
5.5.2	Surface Marking.....	37
<hr/>		
6	Layout of 3D canvas	38
6.1	Drawing canvas	38
6.1.1	Grid type	39
6.1.2	View Orientation	39
6.1.3	Show Marking Volume	40
6.1.4	Show Ruler	41
6.1.5	Visual Styles	42
6.1.6	Trihedral	43
6.2	Project Explorer.....	43

6.3	Shape Tree	44
	Hide/Show/Rename/Delete	44
<hr/>		
7	Managing projects	46
7.1	Before you begin	46
7.2	Preferences	47
7.2.1	Canvas 3D colors	48
7.2.2	Grid spacing.....	48
7.3	Creating a new project.....	48
	Add 3D models to a project.....	49
<hr/>		
8	Creating 3D models	51
8.1	Creating a blank 3D model.....	51
8.1.1	Inserting basic 3D shapes.....	51
8.1.2	Inserting a Box.....	52
8.1.3	Inserting a Cylinder.....	53
8.1.4	Inserting a Cone.....	53
8.1.5	Inserting a Sphere	54
8.2	Create a 3D model from an existing file.....	55
	Supported files.....	56
8.3	Creating a 3D model using 2D shapes.....	56
<hr/>		
9	Modifying 3D models	58
9.1	Viewing options	58
9.1.1	Zoom	58
9.1.2	Pan.....	59
9.1.3	Show Field	60
9.1.4	Rotate.....	60
9.2	Transformations.....	60
9.2.1	Rotate.....	61
9.2.2	Scale.....	64
9.2.3	Mirror	65

9.2.4	Move.....	65
9.2.5	Move to Origin	66
9.2.6	Aligning	67
9.2.7	Face Oriented Alignment.....	68
9.3	Boolean Operations.....	69
9.3.1	Cut.....	70
9.3.2	Fuse.....	71
9.3.3	Common	72
9.4	Solid Operations	73
9.4.1	Selection Mode	73
9.4.2	Face Revolve.....	74
9.4.3	Face Extrusion	75
9.4.4	Fillet.....	77
9.4.5	Lighting.....	78
9.4.6	Deleting the light effects	81

10 Process preparation 82

10.1	Surface Marking process	82
	Adding a 2D Image	84
10.2	Modify 3D surface marking model.....	85
10.2.1	Placement of 2D image.....	85
10.2.2	Viewing surface marking objects.....	87
10.2.3	Running the surface marking project	89
10.3	Engraving process.....	89
10.3.1	Create an engraving process.....	90
10.3.2	Modify an engraving	92
10.3.3	Modify a Section	93
10.3.4	Viewing engraved objects.....	95
10.3.5	Engraving Simulations	95
10.3.6	Running the engraving project	96
10.4	Sample Surface Marking.....	96
10.4.1	Starting ScanMaster™ Designer.....	97

10.4.2	Create the 3D model.....	97
10.4.3	Modify the 3D model.....	99
10.4.4	Transform the 3D model.....	100
10.4.5	Create the 2D image	101
10.4.6	Change the viewing orientation.....	103
10.4.7	Process.....	103
10.4.8	Edit the 2D image.....	104
10.5	Sample engraving	106
10.5.1	Open ScanMaster™ Designer 3D project.....	108
10.5.2	Create the mold	108
10.5.3	Modify the mold	109
10.5.4	Prepare for the engraving process.....	110
10.5.5	Check the engraving simulation	111

11	Appendix	112
11.1	Surface Marking.....	112
11.1.1	Projection.....	112
11.1.2	Wrapping.....	113
11.2	Specifying the axes.....	114
11.2.1	Standard Axis	114
11.2.2	Arbitrary Axis.....	115

List of figures

Figure 1 – Start-up screen	24
Figure 2 – Workspace elements	25
Figure 3 – Recommended workflow.....	26
Figure 4 – Home tab.....	28
Figure 5 – Project tab	31

Figure 6 – Modeling tab.....	33
Figure 7 – Engraving tab.....	35
Figure 8 – SurfaceMarking tab.....	36
Figure 9 – 3D drawing canvas.....	38
Figure 10 – Blank grid.....	39
Figure 11 – Line grid.....	39
Figure 12 – Dotted grid.....	39
Figure 13 – The viewing orientations.....	40
Figure 14 – Canvas with marking volume.....	41
Figure 15 – Canvas without marking volume.....	41
Figure 16 – Canvas with ruler.....	42
Figure 17 – Canvas without ruler.....	42
Figure 18 – Visual styles.....	42
Figure 19 – Project Explorer.....	43
Figure 20 – Shape Tree right-click menu.....	45
Figure 21 – Application Preferences.....	47
Figure 22 – Creating a new project.....	49
Figure 23 – Insert Box.....	52
Figure 24 – Insert Cylinder.....	53
Figure 25 – Insert Cone.....	54
Figure 26 – Insert Sphere.....	54
Figure 27 – Select 3D File dialog.....	55
Figure 28 – View group.....	58
Figure 29 – Transformations group.....	61
Figure 30 – Rotate window – Standard Axis tab.....	62
Figure 31 – Rotate window – Arbitrary axis – Point and Vector.....	63
Figure 32 – Rotate window – Arbitrary axis – Two Points.....	63
Figure 33 – Scale window.....	64
Figure 34 – Mirror window – Standard Axis tab.....	65
Figure 35 – Move window.....	66
Figure 36 – Move to Origin.....	67
Figure 37 – Aligning.....	67
Figure 38 – Center X Align.....	68

Figure 39 – Orient Face window.....	69
Figure 40 – Boolean Operations group	70
Figure 41 – Compound shape on Shape Tree.....	70
Figure 42 – Cut shape.....	71
Figure 43 – Fuse shape	72
Figure 44 – Extracting the common part of the two 3D shapes	73
Figure 45 – Solid Operations group.....	73
Figure 46 – Selection Mode	74
Figure 47 – Face revolved by a standard axis.....	75
Figure 48 – Define the extrusion length.....	76
Figure 49 – Drag to the desired extrusion length.....	76
Figure 50 – Fillet window	77
Figure 51 – Fillets on different selection modes	77
Figure 52 – Lighting window	78
Figure 53 – Illustration of Ambient Light	79
Figure 54 – Ambient Light	79
Figure 55 – Illustration of Directional Light.....	79
Figure 56 – Directional Light.....	80
Figure 57 – Spotlight	80
Figure 58 – Illustration of Point Light.....	81
Figure 59 – Point Light.....	81
Figure 60 – Surface Marking.....	82
Figure 61 – Surface marking process	83
Figure 62 – SurfaceMarking Properties tab.....	83
Figure 63 – Add 2D Image button.....	84
Figure 64 – Add 2D Image.....	84
Figure 65 – Properties of 2D Image	85
Figure 66 – Viewing surface marking objects	87
Figure 67 – Shape and Mapped Image	88
Figure 68 – Shape and Bounding Box.....	88
Figure 69 – Mapped Image Only	89
Figure 70 – Add engraving model in wizard.....	90
Figure 71 – Sectioning options	91

Figure 72 – Sections and Layers of engraving	92
Figure 73 – Engraving Properties.....	93
Figure 74 – Engraved Layers tree.....	94
Figure 75 – Section Properties	94
Figure 76 – Viewing boundary and hatch of engraved objects	95
Figure 77 – Engraving Simulations group	96
Figure 78 – Cylinder on the canvas	98
Figure 79 – Cylinder and Box shape on the canvas	98
Figure 80 – Cylinder shape cut in half on the canvas.....	99
Figure 81 – Half Cylinder and Cylinder shape on the canvas.....	100
Figure 82 – Half Cylinder cut to half pipe shape on the canvas.....	100
Figure 83 – Rotating parameters	101
Figure 84 – Text editor.....	102
Figure 85 – 2D image	102
Figure 86 – Top orientation.....	103
Figure 87 – Add 2D Image.....	104
Figure 88 – Apply Projection	105
Figure 89 – Select the desired face	105
Figure 90 – Projection and Wrapping	106
Figure 91 – Predesigned engraving model.....	107
Figure 92 – Imported 3D model.....	108
Figure 93 – Inserted Cylinder.....	109
Figure 94 – Modified image in different view orientations.....	110
Figure 95 – Specifications of Section 1	110
Figure 96 – Engraving Layers and Sections of the 3D model.....	111
Figure 97 – Projection	113
Figure 98 – Wrapping.....	114
Figure 99 – Standard Axis	115
Figure 100 – Arbitrary Axis – Point and Vector.....	116
Figure 101 - Arbitrary Axis - Two Points	116

List of tables

Table 1 – Revision history	16
Table 2 – Home tab – Standard group	29
Table 3 – Home tab – Edit group.....	29
Table 4 – Home tab – View group.....	30
Table 5 – Home tab – Mark group	31
Table 6 – Project tab – Basic Elements group	32
Table 7 – Project tab – Marking Process group.....	32
Table 8 – Modelling Tab – Primitives group.....	33
Table 9 – Modelling tab – Transformations group.....	33
Table 10 – Modelling tab – Solid Operations group	34
Table 11 – Modelling tab – Boolean Operations group.....	35
Table 12 – Engraving tab – View group.....	36
Table 13 – Engraving tab – Engraving Simulation group	36
Table 14 – SurfaceMarking tab – View group.....	37
Table 15 – SurfaceMarking tab – Surface Marking group.....	37
Table 16 – Icons and commands in the Project Explorer tab.....	43

1 How to use this user manual

1.1 Symbols and signal words

Please be sure that you understand the meanings of the symbols and signal words described below before you move on.

DANGER

... indicates an imminently hazardous situation which, if not avoided, will result in death or serious injury.¹

WARNING

... indicates a potentially hazardous situation which, if not avoided, could result in death or serious injury.²

¹ Serious injury includes blindness, wounds, burns (low and high temperature), electric shock, fractures, and poisoning, etc. which have long-lasting consequences or require hospitalization and/or long-term treatment.

² Serious injury includes blindness, wounds, burns (low and high temperature), electric shock, fractures, and poisoning, etc. which have long-lasting consequences or require hospitalization and/or long-term treatment.

**CAUTION**

... indicates a potentially hazardous situation which, if not avoided, could result in minor or moderate injury.³

**NOTICE**

... indicates a potentially hazardous situation which, if not avoided, could result in property damage and other problems, but not personal injury.

IMPORTANT

... indicates an important information.

TIP

... indicates a practice that facilitates work.

Procedure

... indicates a call to action. After this signal word you must execute one or more steps. We made an exception for DANGER-, WARNING-, CAUTION-, and NOTICE-boxes where we omitted this signal word as avoidance procedures are mandatory there.

1.2 Notation conventions

This user manual uses the following notation conventions.

³ Minor or moderate injury includes wounds, burns, electric shock, etc. not requiring hospitalization and/or long-term treatment.

Notation	Meaning
<u>Underlined</u>	click-able cross reference or hyperlink
Bold	element in the graphical user interface that the user shall click
<i>Italic</i>	name of element in the graphical user interface or emphasized text
Typewriter	text that the user must type in, filename, or path

1.3 Storage and replacement

- Keep this user manual with the product to access it at any time during its lifetime.
- Be mindful of the environment, do not print this user manual unless necessary.
- This user manual is part of the product. If ownership changes, then this user manual must accompany the product.
- You can access the latest copy of this manual on our website:
<https://novantaphotonics.com/>

1.4 Specifics and structure

Novanta reserves the right to make changes to the product covered in this user manual to improve its performance, reliability, or manufacturability. Contents of this user manual are subject to change without notice.

Although every effort has been made to ensure the accuracy of the information contained in this user manual, Novanta assumes no responsibility for inadvertent errors.

This user manual covers the system requirements and overview of the product, and instructions for use.

1.5 Purpose

The aim of this manual is to provide a brief description of the ScanMaster™ Designer software and its functions. This document will mainly focus on the 3D laser marking processes and the capabilities of ScanMaster™ Designer software to do surface marking and engraving processes. Furthermore, this document will guide you through a three-step process to achieve the final 3D laser marking. You will learn the options to create a 3D model, modify as desired and then to perform the process. The features of this application will be demonstrated using simple scenarios which will be helpful for you to understand the process more effectively. You will also find some main points that you should remember when managing a 3D laser marking project in ScanMaster™ Designer software.

TIP

To understand this application and its features perfectly you are required to have a general knowledge about the ScanMaster™ Designer 2D application.

1.6 Target audience and qualification

IMPORTANT

Only target audience, who are listed in the beginning of each instructing section in the following chapters, may perform the activities described there.

The people who perform these activities need to be of age.

The qualification of the target audience is defined below.

Laypersons

without special qualification, who e.g., transport and store the boxed product.

Operators

who are trained by the company that is operating the laser unit that contains the product, in the use of that laser unit and who confirmed the training by signature.

Experts

in electrical engineering or mechatronics with successful training in handling highly sensitive electronic and optical equipment. Experts must be trained by the company that is operating the laser unit that contains the product in the use of that laser unit.

Administrators

with full access to the computer's hardware and software.

1.7 Revision history

Table 1 – Revision history

Revision	Date	Changes from previous revision
A	October 1, 2014	First publication of this manual per ECO 8250
B	June 26, 2015	Increased permissible cooling air pressure to 2 PSIG per ECO 8639.
C	August 8, 2016	Corrected error in Figure 44 and added note on cooling water (pg. 44)
D	March 2024	Updated to new Template

2 General safety instruction

This chapter lists important precautions which users of the product (and anyone else) must observe to avoid injury and damage to property, and to ensure safe and correct use of the product.

2.1 Disambiguation of term 'laser unit'

A *laser unit* is a machine that incorporates a laser device (that is the actual laser), the product and other components.

2.2 Intended use

The product is delivered as an OEM component for integration into a laser unit that uses a class 4 laser.

- Before installing and operating the product, carefully read this user manual for your protection.
- Retain this user manual for future reference.

IMPORTANT

Novanta has no influence over the employed laser device or the overall laser unit.

- Customers assume full responsibility for implementing and maintaining a laser-safe working environment.
- Original equipment manufacturer (OEM) customers assume full responsibility for CDRH (Center for Devices and Radiological Health) certification and compliance with the standards and guidelines required for the CE (European Conformity) label.
- Please contact Novanta for further information about the product and applicable guidelines.

2.3 Reasonably foreseeable misuse

It is considered a misuse if you use the product without incorporating it into a laser unit that complies with the standards and guidelines required for the CE (European Conformity) label.

2.4 Radiation hazards

The product is designed to be operated in conjunction with a class 4 laser.

**WARNING**

Laser radiation can cause severe retinal and corneal burns, burns on the skin, and may pose a fire risk.

- To avoid injury and reduce risk of fire, please follow the control measures and safety guidelines provided by the laser's manufacturer, and those established by your Laser Safety Officer (LSO), Radiation Safety Officer (RSO), or safety department of your business or institution.

 **NOTICE**

Exceeding power handling limits of mirrors and lenses may damage the scanning system. The power handling limits of mirrors and lenses can vary depending on laser parameters such as beam size, laser power, pulse duration, and pulse energy.

- Ensure that the laser parameters are appropriate for the exact scanning system that is in use.

The standard warranty does not cover damage caused by laser power settings that are above the maximum limits for each optic.

- Please contact Novanta if you are not sure about the power limitations of your scanning system.

 **NOTICE**

Back-reflections of laser radiation may damage the scanning system. Any flat or curved surface (including protective windows) between scanning mirrors and the work field will have back-reflections where some percentage of the beam propagating toward the work field will reflect from this surface and will travel back towards the scanning system. Although, the absolute laser power of the backwards propagating beam may be low, the beam may come to a focus on or close to a scanning system optic and the laser damage may occur due to the power density of the laser beam.

- Make sure that any back-reflections from any surface downstream of the scanning system is managed properly.

2.5 System safety



WARNING

Use of controls, adjustments, or procedures other than those specified in this manual may result in component damage, and/or exposure to potential hazards.

- Always follow established industrial safety practices when operating equipment and consulting a competent safety professional.



NOTICE

Errors can cause system damage.

- Always check your application program *before* running it.

2.6 Modifications

Modifications to the product are not permitted.

3 Overview

3.1 What is laser marking?

3D laser marking refers to the laser marking performed on a 3D workspace. 3D laser marking comprises a range of 3D related processes including all types of Surface Markings, Engraving, Sub Layer Laser Engraving and Prototyping. 3D laser marking technology is widely used by many industries such as packaging, automobile manufacturing, jewelry etc.

ScanMaster™ Designer software allows you to create a digital 3D model and apply 2D images to a 3D surface. This application facilitates 3D marking with either projection or wrapping styles.

This application also enables you to do laser engravings by specifying different sections and layers. More detailed information about these features will be discussed in this document.

The marking procedure can be customized using the ScanScript language in which you can experience the advanced capabilities not available through the user interface.

TIP

A detailed description about projection and wrapping styles and their differences will be discussed in section [11.1 Surface Marking](#) on page [112](#).

3.2 Scan controller cards

There are 2 different scan controller cards available which are supported by ScanMaster™ Designer software:

- ScanMaster Controller (SMC)

The SMC is a self-contained controller that provides advanced hardware and software control technology to drive laser scanning systems. The Ethernet connected SMC board is designed to permit remote embedding and control of a scan-head and laser system. It can control 2 scan-heads with up to 3 motion axes each with concurrent laser timing control. It also provides integrated synchronization I/O for connection to factory automation equipment.

- EC1000

The EC1000 is a self-contained controller that provides advanced hardware and software control technology to drive laser scanning systems. The EC1000 control board is specifically designed for remote embedding and control of a scan-head and laser system. It can control 2 scan-heads with up to 3 motion axes each with concurrent laser timing control. It also provides integrated synchronization I/O for connection to factory automation equipment. The EC1000 controller card is the core of the SM1000 Controller Module.

4 Getting started

Use information in this section to install and start the ScanMaster™ Designer software. This section will also introduce the key features of the program as well as recommended tips for establishing a good workflow.

4.1 System requirements

The following software and hardware specifications are the minimum system requirements to install and run ScanMaster™ Designer software on your computer:

- Processor: 1 GHz
- Memory: 1 GB
- Hard disk space: 1 GB
- Display: 1024 × 768 high color (16-bit)
- Operating system:
Windows XP Professional SP3 / Windows Vista SP2 / Windows 7 SP1

4.2 Starting/exiting ScanMaster™ Designer

To start ScanMaster™ Designer

1. On the taskbar, click **Start**.
2. Select **Programs** and locate the **CTI** folder and then the **ScanMaster™ Designer** sub-folder.

3. Click the ScanMaster™ Designer  icon.

The following window will appear:

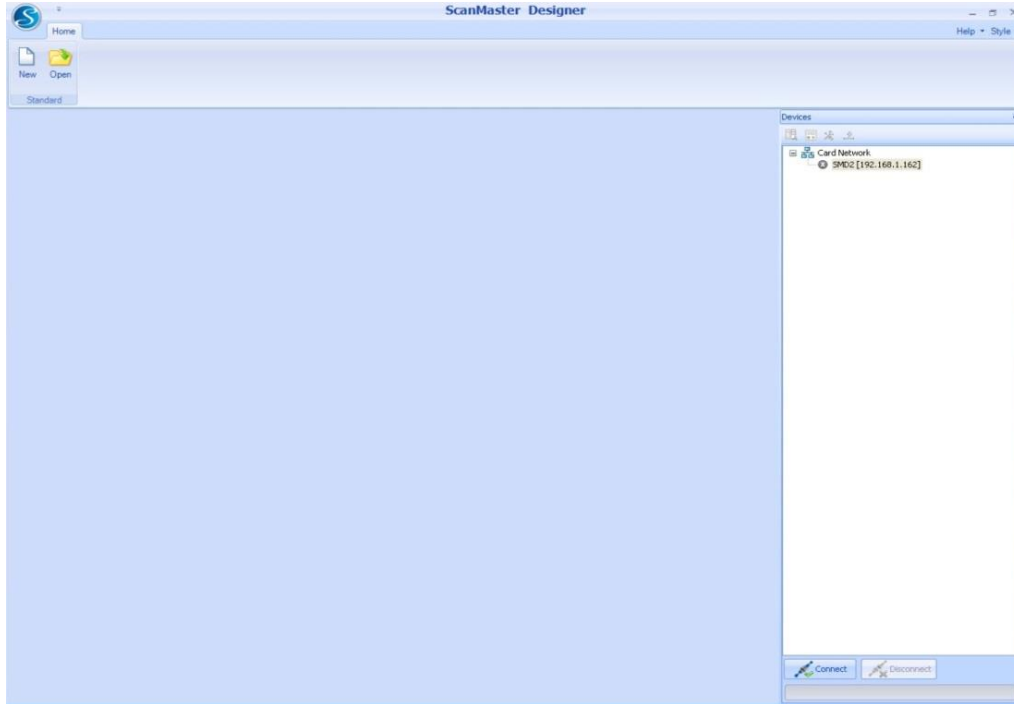

Figure 1 – Start-up screen

4. To start a new project, click **New** on the *Home* tab.

A basic marking job is created by placing different basic shapes such as a box, sphere, cone, or a cylinder on the canvas. Each 3D shape has its own unique properties which can be modified. See chapter 7 on page 46 ff, for detail information about creating projects.

To exit ScanMaster™ Designer

- Close the *ScanMaster Designer* window or select **Exit** from the ScanMaster™ Designer button.

4.3 Workspace elements

Before you can begin using the software you need to be familiar with the ScanMaster™ Designer user interface. Let's start by looking at the main application window and how it's laid out.

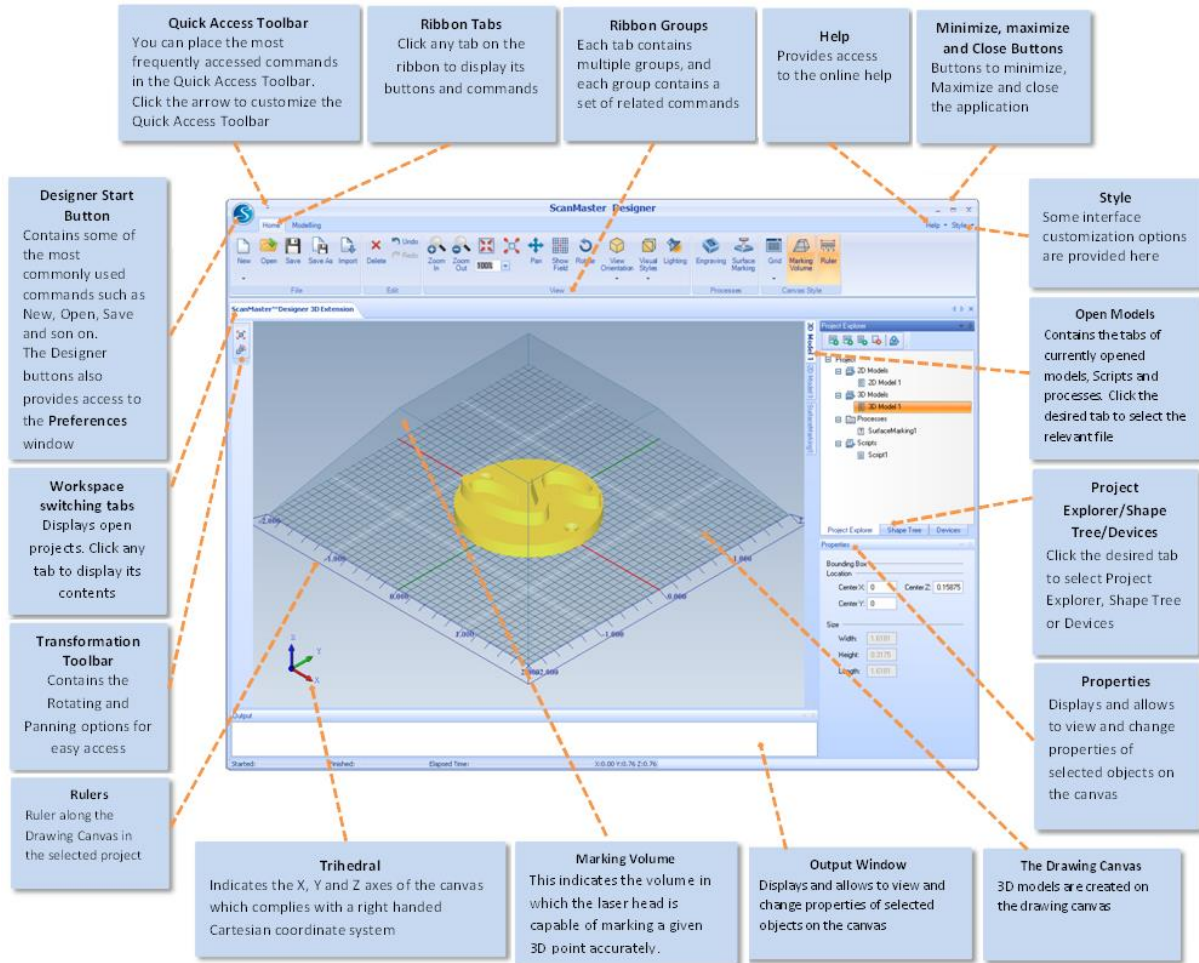

Figure 2 – Workspace elements

4.4 Recommended workflow

The figure below shows the recommended workflow for ScanMaster™ Designer projects.

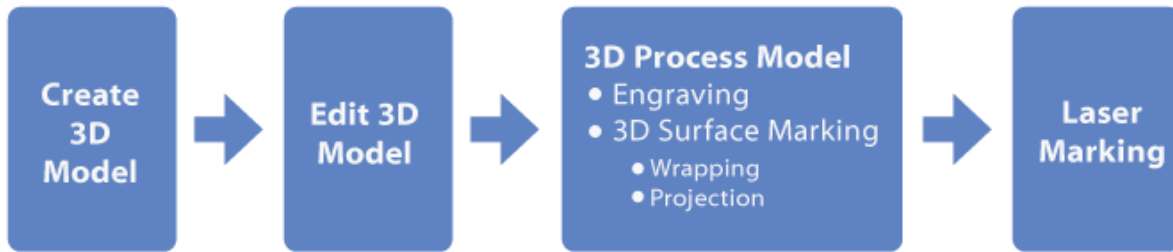

Figure 3 – Recommended workflow

1. Create a 3D Model.

A "Job" is a simple program that contains Models, Processes and Scripts that are executed in the prescribed order. You might want to create a job to make a *Surface Marking process* or an *Engraving process*. The options in ScanMaster™ Designer software, allows you to do these tasks easily.

Insert basic shapes to the drawing canvas by selecting any desired basic 3D shape from the *Primitives* group of the *Modeling* tab. You can insert many shapes to create one 3D model.

TIP

Refer to chapter [8](#) on page [51](#) ff to check detailed information on creating 3D models in a 3D project.

2. Edit the 3D Model.

After you have inserted shapes, you can edit them as preferred. ScanMaster™ Designer software is equipped with a rich collection of editing tools which you can use to edit your 3D models. The options in the *Modeling* tab of the Ribbon will enable you to modify the 3D shapes according to your requirements.

TIP

Refer to chapter [9](#) on page [58](#) ff to check detailed information on how to modify 3D models.

3. Prepare the 3D Process.

To prepare a 3D model to be processed on the laser marking, the commands in the *Engraving* tab and *Surface Marking* will enable you to set the specifications thereby preparing the model to be processed to achieve the output according to your requirements.

TIP

Refer to chapter [10](#) on page [82](#) ff to check detailed information on preparing the 3D model to be processed.

5 ScanMaster Designer interface – The Ribbon

Across the top of the window is the Ribbon. All the application’s functions can be accessed from here and it’s the first place you should look if you’re new to the software and want to get an idea of what you can do with it. As your mouse passes over the menu, tool tips will be displayed.

The Ribbon provides easy access to the ScanMaster™ Designer tools that can be used to create and edit 3D models. Tools are logically grouped into a collection of Tabs. Each tab contains multiple Groups, and each group contains a set of related commands. The Ribbon is docked on top of the ScanMaster™ Designer drawing canvas.

Each item is described in further detail in the following sections.

5.1 Home

The *Home* tab on the *Ribbon* contains the *Standard*, *Edit*, *View*, and *Mark* groups.

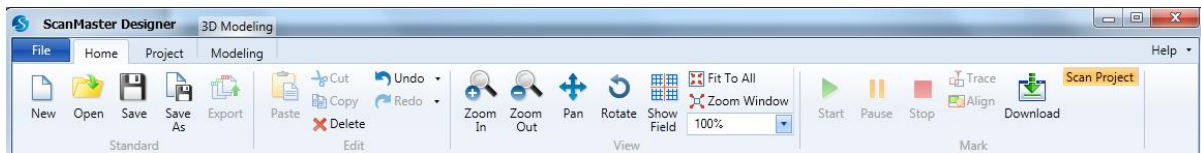







Figure 4 – Home tab

5.1.1 Standard

The *Standard* group allows you to create new, open, save or import 3D and 2D files into the workspace.





Table 2 – Home tab – Standard group

Icon	Command	Description
	New	Opens a new project
	Open	Opens a saved project
	Save	Saves the current project
	Save As	Saves a new project or an existing project which is already opened, in a different name
	Export	Disabled for 3D

5.1.2 Edit

The commands in this group are designed to help you to delete, undo or redo the changes you make to the shapes inserted into the models.

Table 3 – Home tab – Edit group









Icon	Command	Description
	Paste	Disabled for 3D
	Cut	Disabled for 3D
	Copy	Disabled for 3D
	Delete	Deletes all selected objects
	Undo	Reverse the last action performed. You may also undo the last few actions that were performed by clicking the arrow next to Undo

Icon	Command	Description
	Redo	Re-apply the actions that you undid last

5.1.3 View



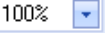



The options in this group enable you to view the drawing canvas in different ways according to your requirement.

Table 4 – Home tab – View group

Icon	Command	Description
	Zoom In	Enlarges the display size of the workspace on the screen
	Zoom Out	Reduce the display size of the workspace on the screen
	Fit to All	Adjust the zoom level to fit the entire contents of the drawing into the current view
	Zoom Window	Zoom Window offers a quick way to zoom a certain area of the drawing canvas
	Pan	Panning allows you to quickly move around the canvas at the same magnification you have currently set
	Show Field	Resets the drawing canvas to the default viewing configurations
	Zoom Factor	The Zoom Factor allows you to zoom in or out by the specified zoom factor
	Rotate	Rotates the drawing canvas

5.1.4 Mark

Table 5 – Home tab – Mark group

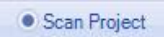
Icon	Command	Description
	Start	Start marking
	Pause	Pause marking
	Stop	Stop marking
	Trace	Trace the outer line of the drawing
	Align	Trace the bounding box of the current job
	Download	Download scanning jobs to a flash memory in the card or to a USB memory
	Scan Project	Scans the whole project including execution of the script

5.2 Project

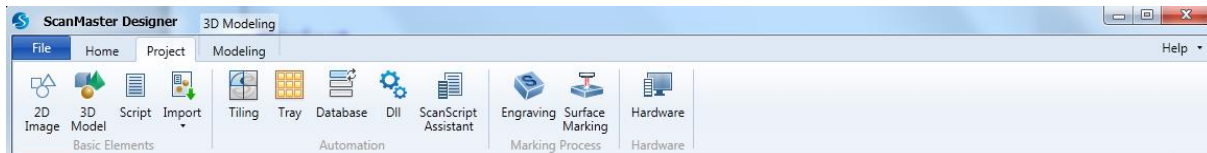





Figure 5 – Project tab

5.2.1 Basic Elements

Add new elements to the project.



Table 6 – Project tab – Basic Elements group

Icon	Command	Description
	2D Image	Add new 2D Image to the project
	3D Model	Add new 3D model to the project
	Script	Add new script to the project
	Import	Allows you to import 2D image, 3D model or script from file

5.2.2 Marking Process

The *Marking Process* group gives you the options of the start of the 3D marking processes.

Table 7 – Project tab – Marking Process group

Icon	Command	Description
	Surface Marking	Creates a new surface marking process on the project
	Engraving	Creates a new engraving process on the project

5.3 Modeling

The *Modeling* tab on the *Ribbon* enables you with many attractive options to modify the 3D shapes to create complex 3D models easily

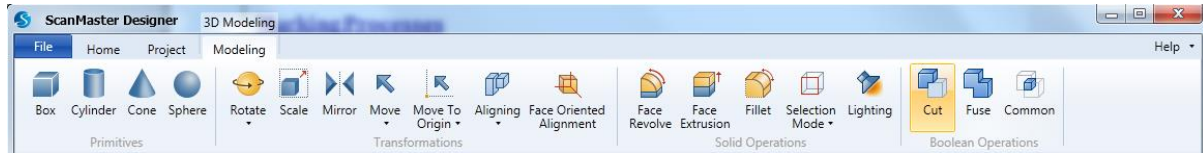





Figure 6 – Modeling tab

5.3.1 Primitives

The *Primitives* group displays, the four basic 3D shapes to insert into the workspace which then you can modify them using the other options in the *Modeling* tab.

Table 8 – Modelling Tab – Primitives group







Icon	Command	Description
	Box	Inserts a three-dimensional cuboid on the drawing canvas according to the given width, height, and length.
	Cylinder	Creates a cylindrical shape according to the given radius and height.
	Cone	Inserts a cone shape according to the specified base and top radius and the height.
	Sphere	Inserts a sphere on the drawing canvas according to the defined radius

5.3.2 Transformations

The *Transformations* group guides you on transforming the 3D shapes as required.

Table 9 – Modelling tab – Transformations group





Icon	Command	Description
	Rotate	Rotates a shape around a specified axis on the canvas

Icon	Command	Description
	Scale	Changes the size of any object drawn or loaded to the canvas
	Mirror	Creates a symmetrical mirror image of the selected shape according to the specified mirror axis
	Move	Moves a shape to a new position you specify related to the current position
	Move to Origin	Moves the selected shape(s) to the origin of the canvas
	Aligning	Aligns two or more objects' bounding boxes to any of the given alignments
	Face Oriented Alignment	Changes the alignment of a selected face so that it is oriented perpendicular to the given axis

5.3.3 Solid Operations

The *Solid Operations* group allows you to modify the 3D shapes in different ways.

Table 10 – Modelling tab – Solid Operations group



Icon	Command	Description
	Face Revolve	Revolves the selected face of the object according to a specified x, y or z axis or arbitrary axis values.
	Face Extrusion	Changes the dimension of an object by extending a selected face according to a specified extrusion length.
	Fillet	Curves the shape of the selected mode, by a given radius
	Selection Mode	Selects the 3D shapes by faces, edges, vertices or neutral.

Icon	Command	Description
	Lighting	Changes the lighting effects from different directions.

5.3.4 Boolean Operations

This group allows you to modify two selected 3D shapes in terms of *Cut*, *Fuse* and *Common*.

Table 11 – Modelling tab – Boolean Operations group

Icon	Command	Description
	Cut	This command gives you the option of cutting a particular overlapped section of the first selected 3D shape
	Fuse	The fuse command allows you to join two or more 3D objects together to make one 3D shapes
	Common	Extracts the common section of two selected 3D shapes

5.4 Engraving

The *Engraving* tab on the *Ribbon* provides you the capability to adjust the 3D model for engraving.

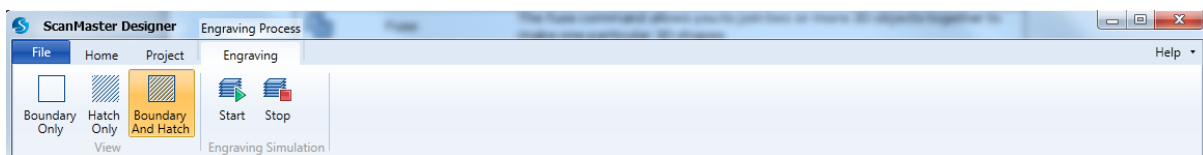





Figure 7 – Engraving tab

5.4.1 View

The options in this group enable you to view engraved objects in different views.



Table 12 – Engraving tab – View group

Icon	Command	Description
	Boundary Only	Allows you to view only boundary of the engraving object
	Hatch Only	Allows you to view only the hatch of the engraving object
	Boundary and Hatch	Allows you to view both the boundary and hatch of the engraving object.

5.4.2 Engraving Simulation

The options in this group allow you to preview specified sections of your engraving process.

Table 13 – Engraving tab – Engraving Simulation group

Icon	Command	Description
	Start	Starts the preview of the engraving process
	Stop	Stops the preview of the engraving process

5.5 SurfaceMarking

The *SurfaceMarking* tab on the *Ribbon* provides the capability to adjust the 3D model for surface marking.

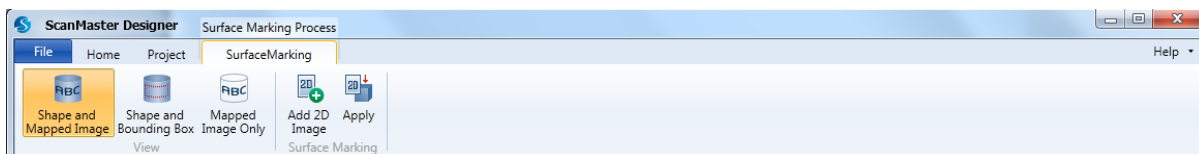





Figure 8 – SurfaceMarking tab

5.5.1 View



The options in the *View* group, provides different ways to visualize the 3D model.

Table 14 – SurfaceMarking tab – View group

Icon	Command	Description
	Shape and Mapped image	Displays the 3D model and the mapped image
	Bounding Box and Shape	Displays the 3D model and the bounding box of the mapped image
	3D Image only	Displays only the mapped image

5.5.2 Surface Marking

Table 15 – SurfaceMarking tab – Surface Marking group

Icon	Command	Description
	Add 2D Image	This command allows you to add a 2D image to the canvas for processing
	Apply	The Apply command allows you to apply the 2D image to your 3D model that you have created

6 Layout of 3D canvas

6.1 Drawing canvas

The 3D drawing canvas is the 3D workspace which allows users to see the graphical representation of a 3D model and work with it.

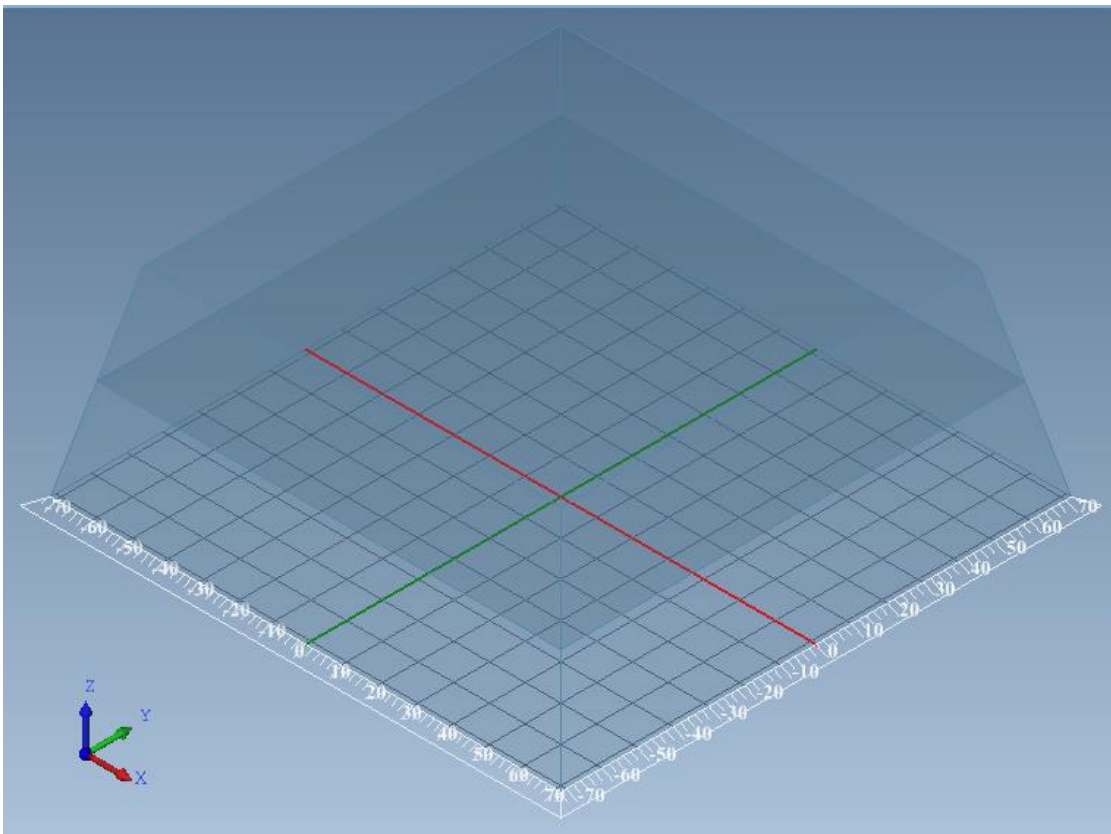



Figure 9 – 3D drawing canvas

6.1.1 Grid type

The *Grid* options are accessible by clicking on the **Grid**  button below the canvas.

This command helps you to perfectly align shapes and drawings along the grid lines and points.

The following images show the appearance of the different grid styles.

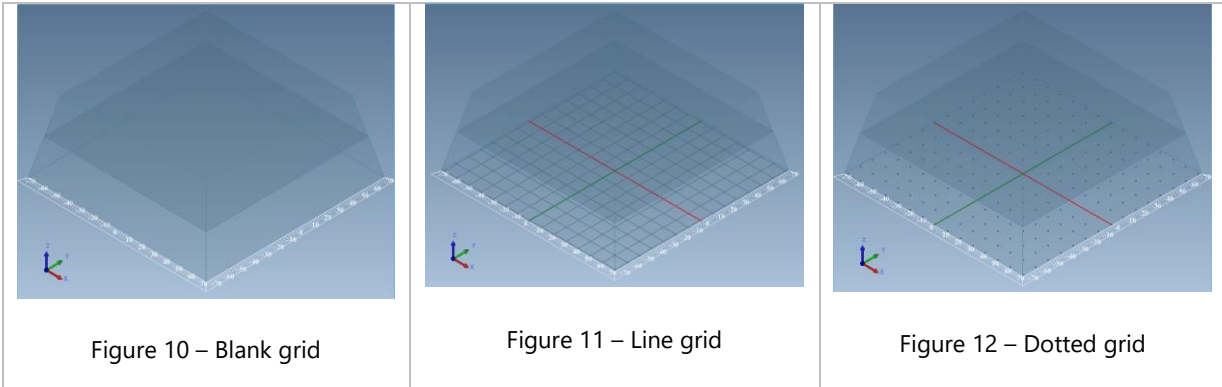

6.1.2 View Orientation

The *View Orientation* options are accessible by clicking on the **View Orientation**  button below the canvas. This command helps you to change the view of the drawing canvas in different directions.

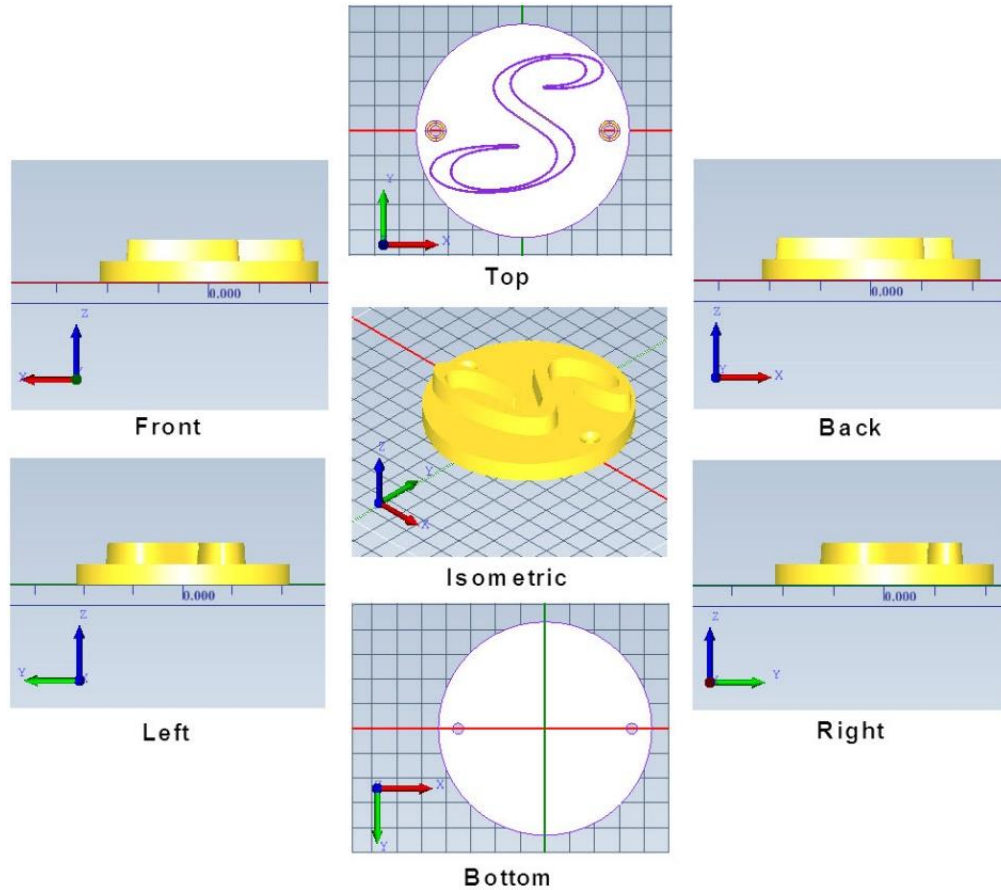

Figure 13 – The viewing orientations

TIP

The objects in the canvas will be displayed in the Isometric view by default.

6.1.3 Show Marking Volume

The marking volume is indicated by a transparent pyramid shape. This represents the volume in which the scan head is capable of marking a given 3D point accurately.

You can access the *Marking Volume*  button below the canvas.

- Click on the **Marking Volume** button to show/hide the marking volume.

The following images show the appearance with and without Marking Volume.

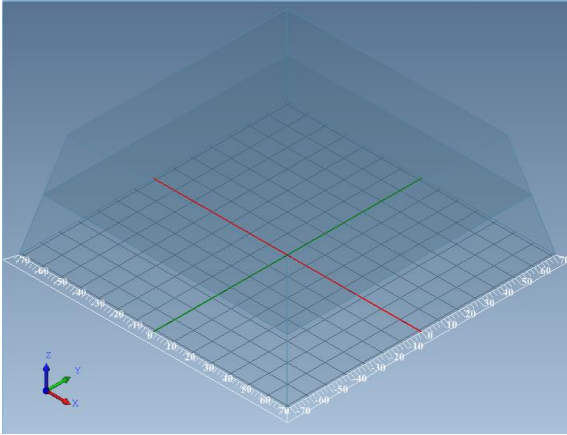

Figure 14 – Canvas with marking volume

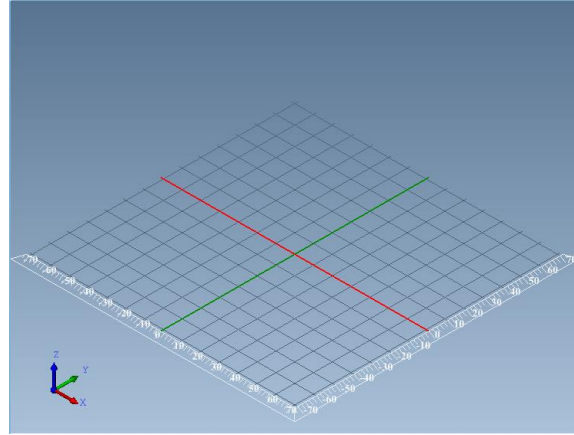



Figure 15 – Canvas without marking volume

Any 3D models or sections of 3D models which are placed beyond the marking volume will not be marked by the scan head.

6.1.4 Show Ruler

- Click on the **Ruler**  button below the canvas to show/hide the ruler.

The following images show the appearance with and without the ruler.

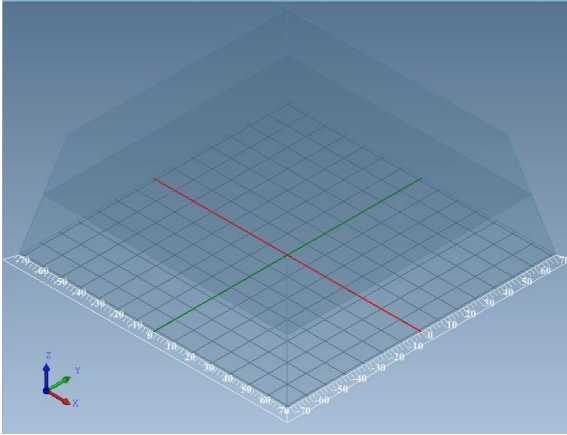

Figure 16 – Canvas with ruler

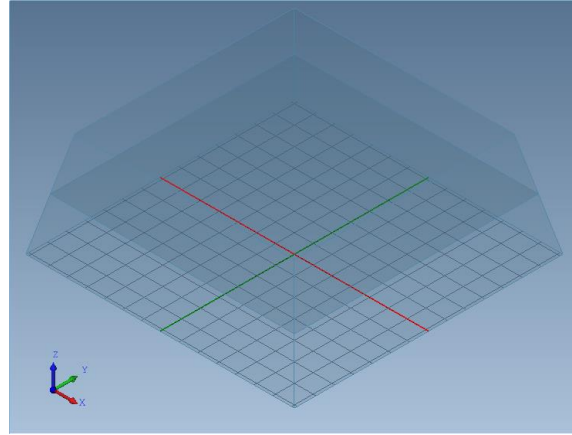



Figure 17 – Canvas without ruler

A ruler is displayed along the X and Y axis of the drawing canvas to help you adjust the position of the 3D model in the drawing canvas.

The position of the 3D model can be specified by defining the X and Y values in the *Properties* of the 3D model.

6.1.5 Visual Styles

The *Shaded* and *Wire Frame* options are accessible by clicking on the **Visual Styles**  button below the canvas.

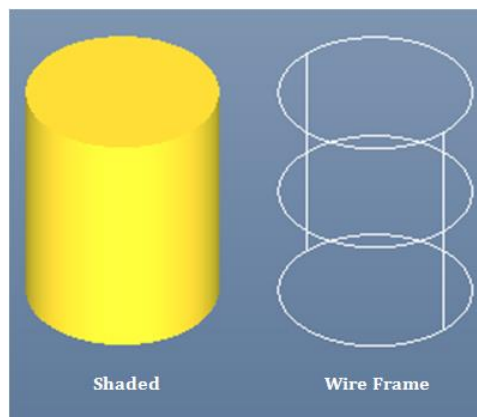



Figure 18 – Visual styles

6.1.6 Trihedral

The trihedral  at the bottom left corner of the canvas indicates X, Y and Z axes of the grid which complies with a right-handed Cartesian coordinate system.

6.2 Project Explorer

A project can have several 3D models and 2D images, marking processes and scripts. Any 2D image, 3D models, project or script created in the ScanMaster™ Designer software is visible on the *Project Explorer* tab, in a hierarchical structure. The current project is visible in the top level with corresponding 2D images, 3D models, processes, and the script files below it.

To view the elements on the project explorer, click on the **Project Explorer** tab which is on the top-right corner of the application.

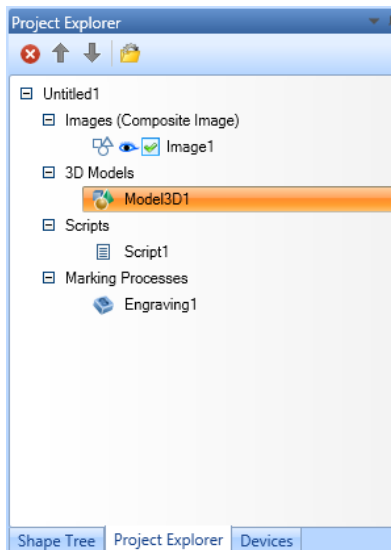





Figure 19 – Project Explorer

The following table describes the commands and icons displayed in the *Project Explorer* tab.

Table 16 – Icons and commands in the Project Explorer tab



Icon	Command	Description
------	---------	-------------

Icon	Command	Description
	Delete	This command deletes any selected element in the project explorer
	Move Up	This command will move the selected item one step up in the current list
	Move Down	This command will move the selected item one step down in the current list
	Project Settings	This command allows you to customize the project settings

6.3 Shape Tree

The *Shape Tree* displays all the shapes inserted on the current model or process. To access the shape tree, click on the **Shape Tree** tab which is on the top-right corner of the application.

Hide/Show/Rename/Delete

The shape can be hidden, shown using the  /  icons and rename or delete the shapes using the right-click options in the *Shape Tree* tab.

1. Right-click on the shape from the **Shape Tree**.

You will see the menu as shown in the figure below.

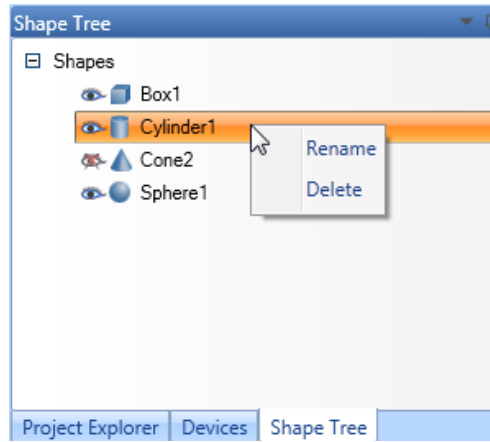

Figure 20 – Shape Tree right-click menu

2. Click the **Rename** command to change the default name of the selected shape of the shape tree.
3. Click the **Delete** command to delete the selected shape from the project.

7 Managing projects

A clear understanding of 3D project management in ScanMaster™ Designer will ensure an efficient workflow. This section guides you on certain basic areas which should be considered when managing a 3D project.

7.1 Before you begin

Before you create a new 3D project, you need to understand and focus on certain areas to gain optimal results:

1. You should be familiar with the basics of ScanMaster™ Designer software interface. Refer to sections [4.2 Starting/exiting ScanMaster™ Designer](#) on page [23](#) and [4.3 Workspace elements](#) on page [25](#) to have a clear idea about the application.
2. Get familiar with the supportive 3D file formats, project structure and the project default settings.
3. You can import 3D models from **STEP**, **IGES** and **STL** formats.
4. Understand the concept of changing the measurement units of the projects. The measurement units of the 3D models that you insert into your canvas depend on the settings of the **Default Units** and **Grid Spacing** that you set in **Project Settings** therefore make sure that you have an idea about your measurement settings when you specify the parameters of any 3D models in your project.

TIP

Please refer to chapter 5 *Managing Projects* in the *ScanMaster™ Designer 2D – User Manual* to check more facts that you should consider before you begin a 2D project in ScanMaster™ Designer 3D Extension.

7.2 Preferences

Preferences are the project default settings for any new project created in ScanMaster™ Designer software. They are organized as *General*, *Editors*, *2D Scanning* and *3D Scanning* tabs.

The *Preferences* window is accessed by clicking the **ScanMaster™ Designer**  button on the upper-left corner of the screen.

You will find the following *Application Preferences* window.

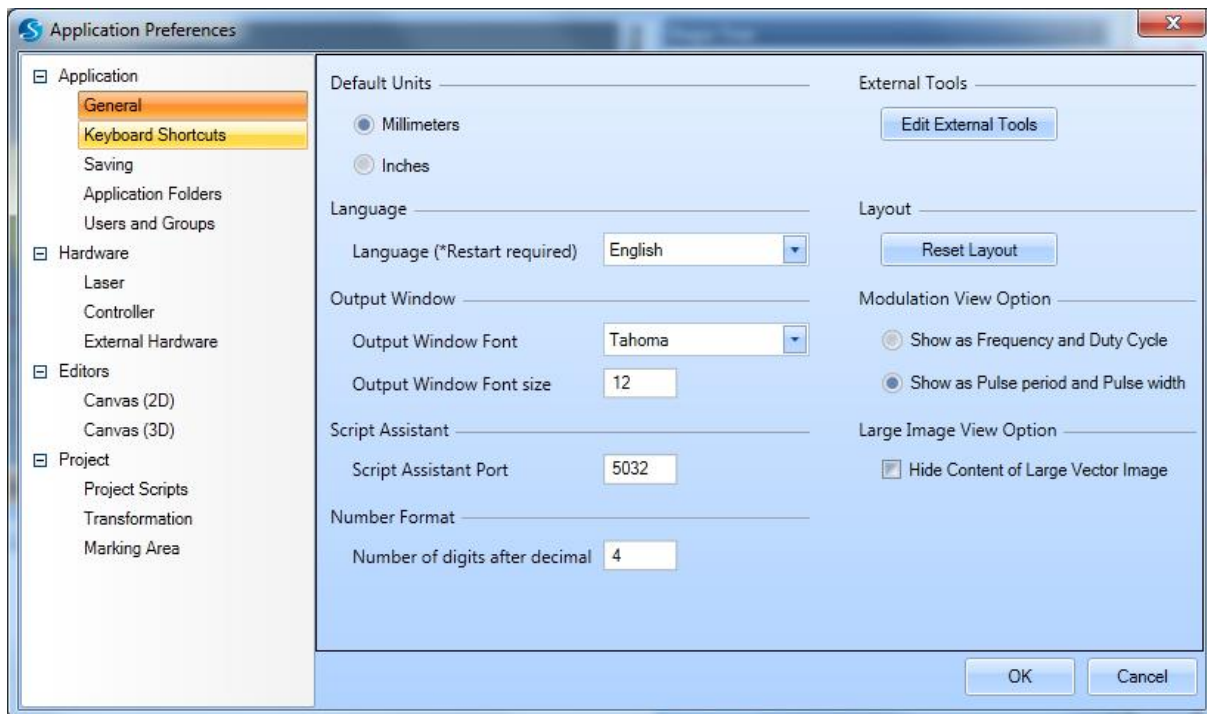



Figure 21 – Application Preferences

7.2.1 Canvas 3D colors

The *Designer Colors (3D)* tab allows adjustment of the colors of the 3D workspace. As seen in the figure below, the application allows you to customize the colors of the objects in the drawing canvas, the rulers, ruler text, marking area, marking area lines, upper and lower backgrounds, grid lines and the surface marking logo.

To change the color of an element

1. Click the drop-down color chart button  and select the required color from either the preset colors or by means of the **More Colors** option, where you could specify RGB values to match a specific color.

– OR –

Click the **Use Defaults** button to reset the colors to their original state.

2. Click on the **OK** button to save the changes you made to the colors of the layout and exit.
3. Click **Cancel** if you want to exit without saving.

7.2.2 Grid spacing

You can display the *Grid* as a rectangular pattern of lines or dots. The spacing between the grid lines is called "*Grid spacing*". Grid spacing can be measured in either millimeters or inches.

TIP

Please refer to chapter 5 *Managing Projects* of the *2D User Manual* for details on *General*, *2D Scanning and Editors* > *Designer Colors (2D)* tabs.

7.3 Creating a new project

To create a new project

- Choose **New**  from the *Home* tab or press **Ctrl + N**.

A new drawing canvas will be opened.

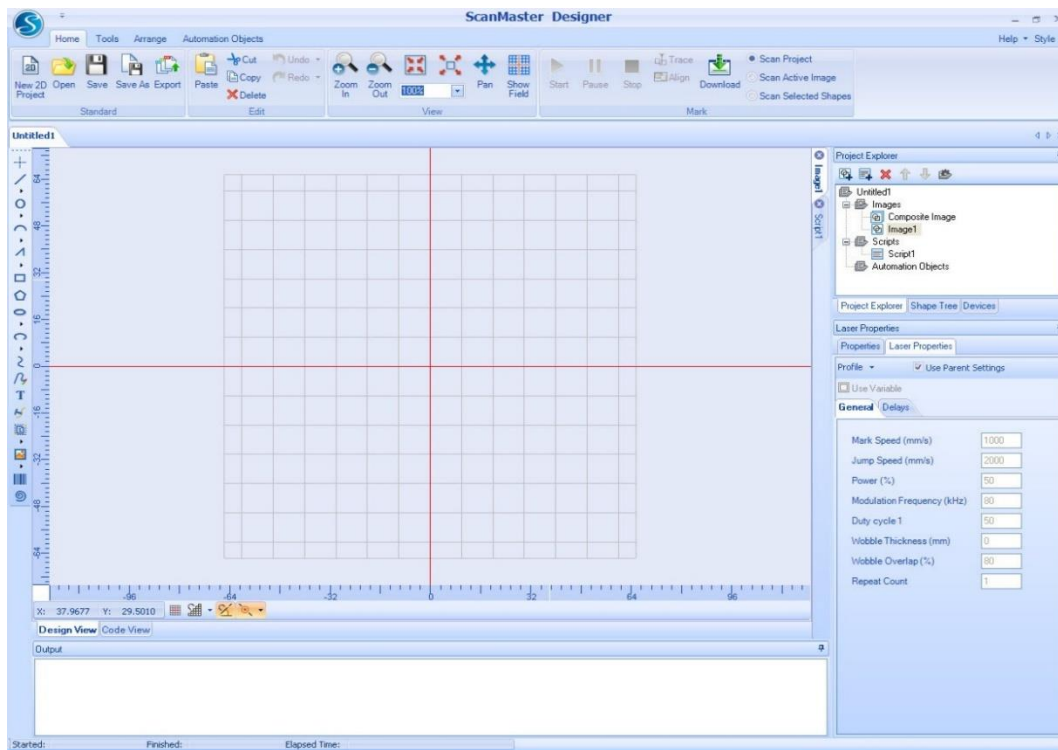



Figure 22 – Creating a new project

Add 3D models to a project

You may create several 3D models per project.

1. Go to **Project** Ribbon tab.
2. Click the **3D model**  button on the *Basic Elements* group.

A new 3D model will be added to the project, and it will be visible on the Project Explorer window as well.

TIP

Refer to chapter [8](#) on page [51](#) ff to get more details on creating 3D models on your 3D project.

Refer to chapter [5](#) *Managing Projects* of the *2D User Manual* for details on opening and saving a project.

8 Creating 3D models

The first step in the 3D model marking process is creating a 3D model. The ScanMaster™ Designer software allows you to create 3D models according to your requirements in different ways. You can create a 3D model from the beginning, or you can import an existing 3D model to your project.

8.1 Creating a blank 3D model

To create a new 3D model of your own

1. Go to **Project** Ribbon tab.
2. Click the **3D model**  button on the Basic Elements group.

A new 3D model will be added to the project, and it will be visible on the *Project Explorer* window as well.

A 3D model can be a collection of many 3D shapes. ScanMaster™ Designer software allows you to create any kind of 3D models using the basic 3D shapes provided to you.

8.1.1 Inserting basic 3D shapes

The ScanMaster™ Designer software comprises four basic 3D shapes including *Box*, *Cylinder*, *Cone*, and *Sphere*. You can access these shapes in the *Primitives* group of the *Modeling* tab. Each shape can be inserted on to the drawing canvas by specifying the relevant geometrical parameters.

8.1.2 Inserting a Box

To insert a 3D box shape

1. Click on the **Box**  command in the *Primitives* group.

The figure below shows the specifications of the parameters associated with the box shape and its output.

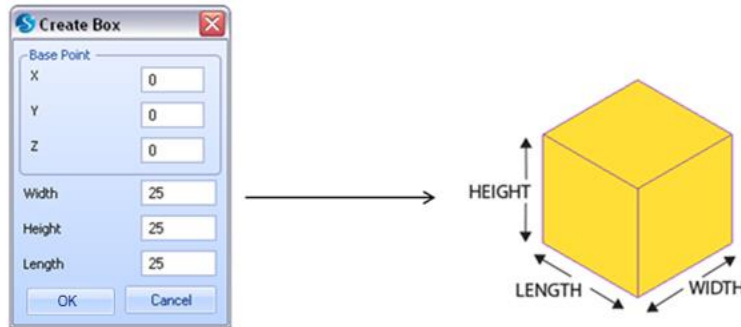

Figure 23 – Insert Box

The *Base Point* refers to the position of the *Box* on the drawing canvas. The base point is defined as the minimum **X**, **Y** and **Z** point of the box.

The **Width** refers to the distance along the x axis.

The **Length** refers to the distance along the y axis.

The **Height** refers to the distance along the z axis.

2. Click **OK** to confirm your specifications.

8.1.3 Inserting a Cylinder

To insert a cylindrical shape

1. Select the **Cylinder**  command on the *Primitives* group of the *Modeling* tab. The figure below shows the specifications of the parameters associated with the *Cylinder* shape and its output.

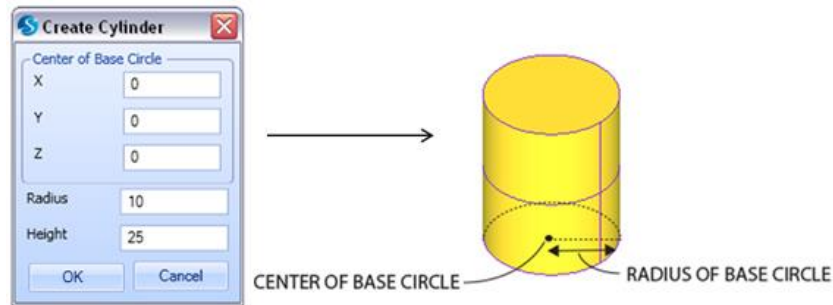

Figure 24 – Insert Cylinder

The *Center of Base Circle* represented by the **X**, **Y** and **Z** coordinates refers to the center point of the base circle.

The **Radius** refers to the radius of the base circle.

The **Height** refers to the distance measured along the axis of the cylinder.

2. Click **OK** to confirm your specifications.

8.1.4 Inserting a Cone

To insert a cone shape to the drawing canvas

1. Select the **Cone**  command from the *Basic* group.

The figure below shows the specifications of the parameters associated with the *Cone* shape and its output.

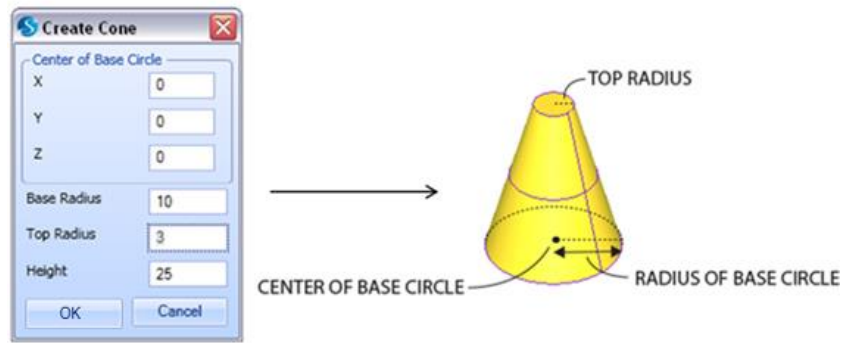

Figure 25 – Insert Cone

The *Center of Base Circle* represented by the **X**, **Y** and **Z** coordinates refers to the center point of the base circle.

The **Base Radius** refers to the radius of the base circle.

The **Top Radius** refers to the radius of the top circle.

2. Click **OK** to confirm your specifications.

8.1.5 Inserting a Sphere

To insert a sphere shape on the drawing canvas

1. Select the **Sphere**  command from the *Basic* group. The figure below shows the specifications of the parameters associated with the *Sphere* and its output.

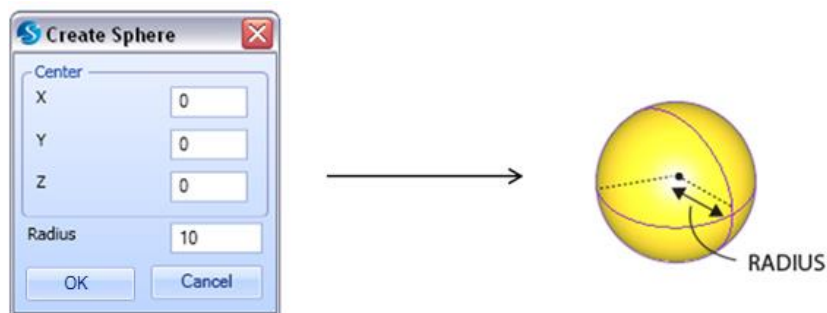

Figure 26 – Insert Sphere

The *Center* represented by the **X**, **Y** and **Z** coordinates refers to the center point of the *Sphere* on the drawing canvas.

The **Radius** refers to the radius of the *Sphere*.

2. Click **OK** to confirm your specifications.

TIP

You can create complex 3D models by inserting many 3D shapes and modifying them to make one whole 3D model. Refer to chapter 9 on page 58 for more information on modifying 3D models.

8.2 Create a 3D model from an existing file

ScanMaster™ Designer software allows you to import existing 3D models to your project.

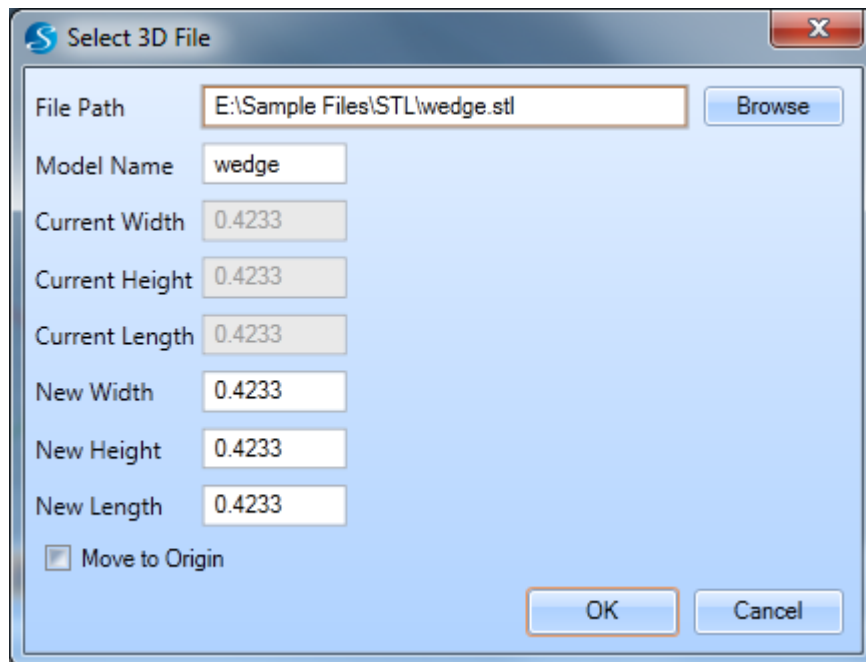



Figure 27 – Select 3D File dialog

1. Go to **Project** Ribbon tab.
2. Select the **3D model**  button from the import  drop down button.
The 3D file dialog will be opened.
3. Click **Browse** button to browse the existing 3D model file location.
The *Open* dialog box will be displayed.
4. Select the desired 3D model file and click **Open**.
The location of the file will be identified and displayed in the *File Path*.
The current width, height and length of the 3D model will be identified automatically by the system.
5. If you want to change the width, height, and length of the importing model, specify the values in the respective **New Width, Height, and Length** fields.
6. Check the **Move to Origin** check box to move the importing 3D model to the origin of the canvas.
7. Click **OK**.

Supported files

ScanMaster™ Designer software supports the following file formats to be imported to the 3D projects.

- Standard for the Exchange of Product data (STEP)
- Initial Graphics Exchange Specification (IGES)
- STereo Lithography (STL)

8.3 Creating a 3D model using 2D shapes

The ScanMaster™ Designer supports 2D shape extrusion to create 3D shapes. Any simple or composite closed shape can be extruded in the Z axis direction to form a 3D shape by simply specifying the height of the expected 3D shape.

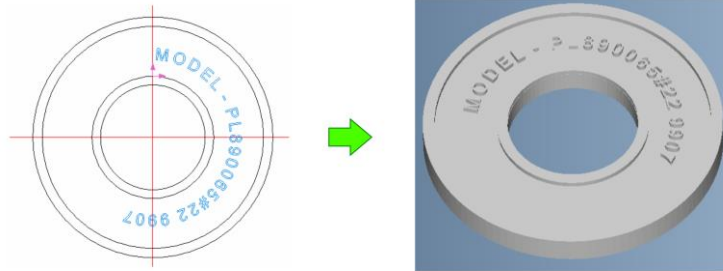

1. With a 3D model in place, select the desired 2D shape from the 2D canvas.
2. Right-click on the selected shape and select **Extrude** from the pop-up menu.

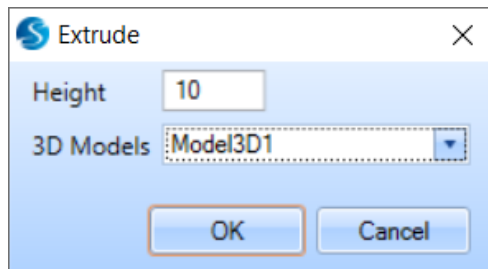

3. Specify the desired height for the extruded 3D shape.
4. Select the 3D model from the drop-down list, onto which this extruded shape adds.

You may use the multiple shape selection facility of the canvas either by drawing a selection box using the mouse or by selecting the required shapes while pressing the SHIFT button. Right click anywhere on the selected shapes to access the extrude menu.

TIP

Only closed shapes or closed composite shapes are allowed. For example, any lines or open polylines will not be allowed.

9 Modifying 3D models

Once the 3D model is created, the next step is to modify the created models to create more complex 3D models and thereby achieve the desired output. This chapter will guide you through various modification features provided by ScanMaster™ Designer software.

9.1 Viewing options

The *View* group in the *Home* tab provides a rich set of view port-oriented operations. You can change the view of the 3D canvas according to your requirements to help you navigate to each location of the model and observe it in detail.

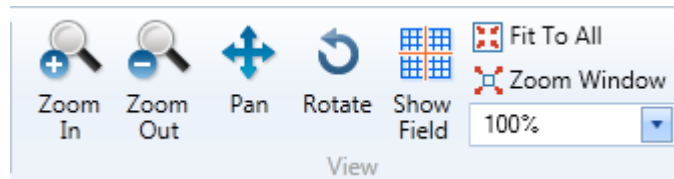



Figure 28 – View group

9.1.1 Zoom

The *Zoom* commands are available in the *Home* > *View* section. *Zoom* commands are very useful when having to go back and forth between editing small details at a magnified level and for checking the overall picture at a minimized level.

To Zoom In / Out

1. Go to the **Home** > **View** group.

2. Click **Zoom In**  / **Zoom Out**  , or select a more exact zoom percentage in the **Zoom Factor** percentage menu.

Zoom In increases the magnification level of a drawing on the canvas.

Zoom Out reduces the magnification level of a drawing on the canvas.

TIP

You can also use the mouse wheel to increase or reduce the magnification level of the canvas. Hold the CTRL key pressed while using the mouse wheel for a finer step change of the magnification level.

Zoom Window

Zoom Window offers a quick way to view a certain area of the drawing.

1. Click **Zoom Window**  .
2. Select a certain area of the drawing.

Fit To All

Fit to All allows resizing the drawing canvas width/height to display it in any screen size.

- Click **Fit to All**  .

9.1.2 Pan

Panning allows you to quickly move around the canvas at the same magnification you have currently set.

1. Go to the **Home > View** group.
2. Click Pan  .
3. Click on the drawing canvas and drag it away to the location you desire and release.

– OR –

1. Hold the CTRL key and the middle mouse button pressed while dragging the cursor on the canvas.
2. Release the mouse button when the drawing is at the position you desire.

TIP

The cursor image changes to a hand cursor when panning is activated.

9.1.3 Show Field

The *Show Field* command in the *Home > View* group resets the drawing canvas to the default viewing configurations.

- Click on the **Show Field**  button to view the default viewing configurations of the drawing canvas.

9.1.4 Rotate

The **Rotate** function allows you to rotate the drawing canvas according to your requirements.

- Click on the **Rotate**  button on the *View* group of the *Home* tab.

– OR –

Hold the middle mouse button pressed while dragging the cursor on the drawing canvas to rotate into the desired angle.

9.2 Transformations

Transformation options can be accessed in the *Transformations* group on the *Modeling* tab. This group provides basic transformation options including rotation, scaling, mirroring, moving to the origin, moving to a desired location and face-oriented aligning.

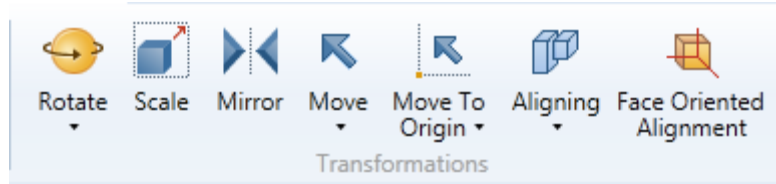



Figure 29 – Transformations group

9.2.1 Rotate

You can use the *Rotate* command to rotate the 3D model around a standard axis (X, Y, Z) or an arbitrary axis and the angle.

To rotate a 3D model

- Select the appropriate model and click on the **Rotate**  command in the *Transformations* group.

You can either specify the **Standard Axis** parameters or else specify the **Arbitrary Axis** parameters to rotate a 3D model.

Standard axis

1. To rotate a 3D model by specifying the standard axes select the desired axis and define an **Angle** to be rotated.
2. Click **OK** to confirm.



Figure 30 – Rotate window – Standard Axis tab

Arbitrary axis

Rotation by an *Arbitrary Axis* can be done in two ways. You can either select to rotate by defining a **Point and Vector** or by defining **Two Points** on the 3D workspace.

Point and Vector

1. To rotate by a point and a vector select the **Point and Vector** option from the *Arbitrary Axis* tab.
2. Define the point by specifying the **X**, **Y** and **Z** values.
3. Define the direction vector by specifying the **I**, **J** and **K** values.
4. Define the rotation **Angle**.
5. Click **OK**.



Figure 31 – Rotate window – Arbitrary axis – Point and Vector

Two Points

You can rotate 3D models by defining two 3D points as shown in the figure below.

1. Define the first point by specifying the **X**, **Y** and **Z** values.
2. Define the second point by specifying the **X2**, **Y2** and **Z2** values.



Figure 32 – Rotate window – Arbitrary axis – Two Points

TIP

Refer to subsection [11.2.2](#) on page [115](#) for more details on specifying the arbitrary axes.

9.2.2 Scale

This function allows you to change the size of any 3D model on the canvas.

To access the Scale command

1. Click the **Scale**  button of the *Transformations* group.

You will see the following **Scale** dialog box.

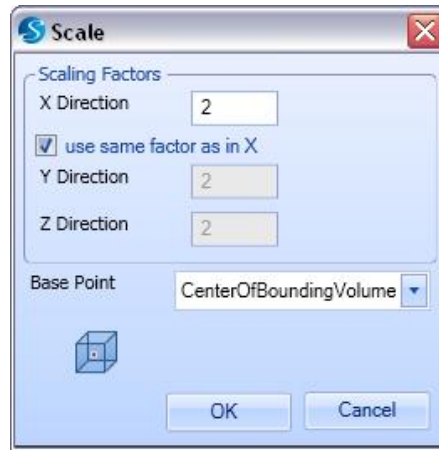

Figure 33 – Scale window

2. Define scale factors for **X**, **Y** and **Z** directions in the appropriate text boxes.
3. Check the **use same factors as in X** check box to use the same scale factor given for the x direction for the other two directions also.
4. Select the **Base Point** as required.

The selected base point will be kept fixed while scaling.

TIP

The *Scaling Factors* should be greater than zero and if the value of the scale factor is 1 then there will be no change to the size of the object.

9.2.3 Mirror

This option will create a symmetrical mirror image of the selected 3D model according to the specified values in the *Standard Axis* or *Arbitrary Axis* tabs. You can access the **Mirror**  command from the *Transformations* tab.



1. Select the 3D model you want to mirror.
2. Click the **Mirror**  command in the *Transformations* group.



Figure 34 – Mirror window – Standard Axis tab

3. Define the **Standard Axis** values on the *Mirror* dialog box or select the *Arbitrary Axis* tab to mirror with respect to an arbitrary axis.
4. Select either **Point Vector** or **Two Points** options and define the respective values of the mirror axis.
5. If you check **Keep original object**, the original 3D model will remain on the drawing canvas.

9.2.4 Move

This function allows you to move a 3D model relatively to a specified direction. The **Move**  command can be accessed in the *Transformations* group.

1. To move a 3D shape, select the 3D shape you want to move and click the **Move**  command found in the *Transformations* group.



Figure 35 – Move window

2. The **Delta X**, **Delta Y** and **Delta Z** values represent the relative values of the move along the respective directions.
3. Specify the **Delta** values of the **X**, **Y** and **Z** directions.
4. Click **OK** to confirm.

9.2.5 Move to Origin

This command in the *Transformations* group allows you to the move the reference point of the 3D object to the origin.

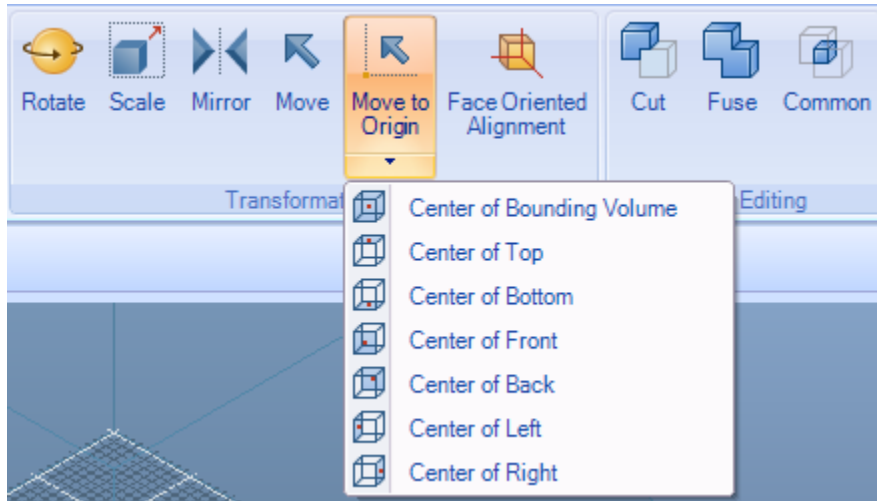

Figure 36 – Move to Origin

9.2.6 Aligning

This function allows you to align two or more objects by their bounding boxes according to any of the given alignments.

You can access the **Aligning** command in the *Transformations* group on the *Modeling* tab.

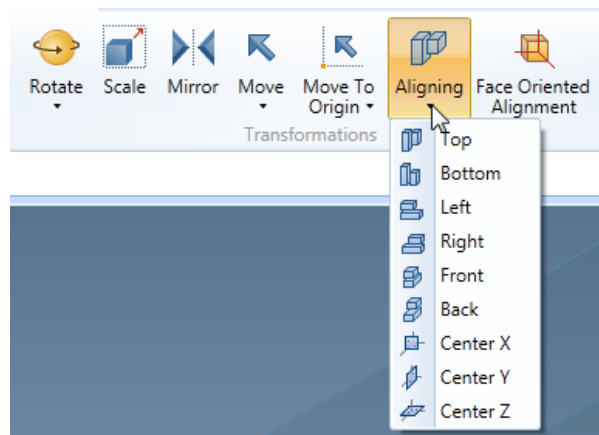

Figure 37 – Aligning

To align the objects

1. Select the desired 3D objects you want to align.

2. Click on the drop-down arrow of the **Aligning** command to view the available alignment options.
3. Select a suitable alignment option from the *Aligning* list.

The **Center X** Align function will align the center of the bounding boxes of the two selected shapes to the center X value of the first selected shape.

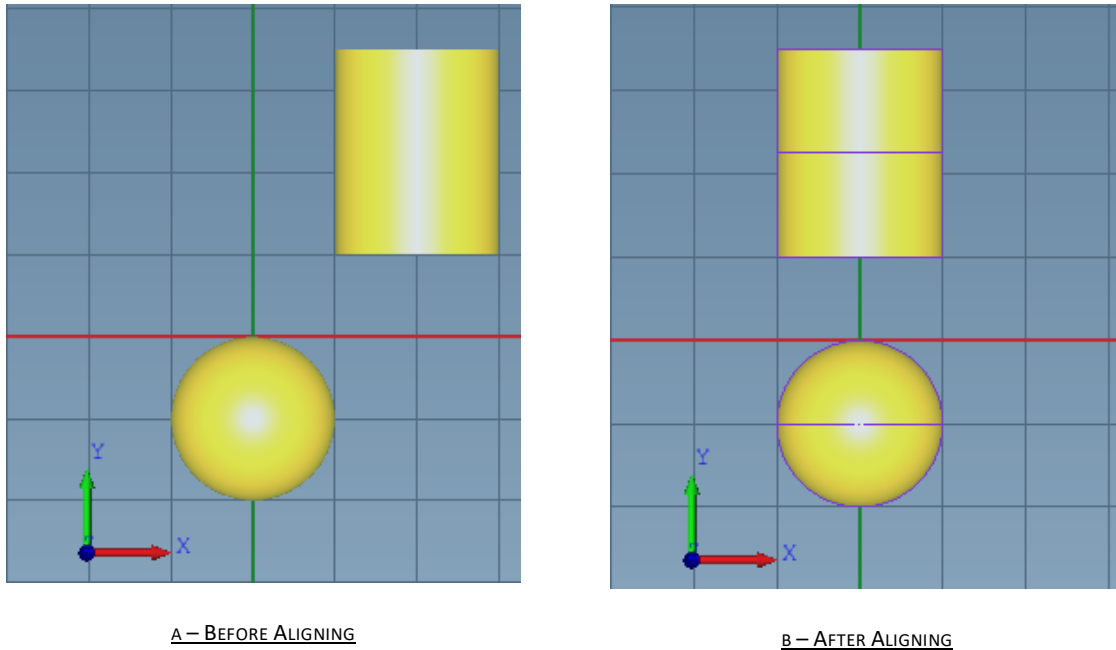

Figure 38 – Center X Align

The **Center Y** Align function will align the center of the bounding boxes of the two selected shapes to the center Y value of the first selected shape.

The **Center Z** Align function will align the center of the bounding boxes of the two selected shapes to the center Z value of the first selected shape.

9.2.7 Face Oriented Alignment

This function will change the orientation of the 3D shape in a way that the selected face will be turned to the specified direction.

To change the face-oriented alignment of a selected object

1. Click the **Face Oriented Alignment**  command from the *Transformations* group.

You will find the following window.

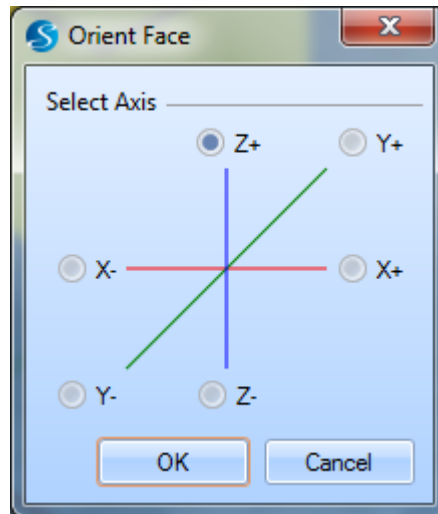

Figure 39 – Orient Face window

2. To change the face-oriented alignment you must first select the **Faces** command from the *Selection Mode* list in the *Solid Operations* group.
3. Select the 3D shape which you want to change the face-oriented alignment.
4. Select any of the face-oriented alignment options from the *Face Oriented Alignment* list.

TIP

For more details on *Solid Operations* group refer to section [9.4](#) on page [73](#).

9.3 Boolean Operations

Boolean Operations allows you to modify the 3D objects by cutting, fusing, and extracting common areas of the 3D objects.

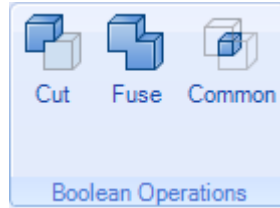

Figure 40 – Boolean Operations group

The following *Boolean Operations* were done by inserting a **Cylinder** with a **Height** of 25 and a **Radius** of 10 and a **Sphere** with a **Radius** of 10 and **Center Z** as 25.

TIP

When you perform any *Boolean Operation*, the original shapes will become a single 3D object. The *Shape Tree* will display it as one shape as shown in the figure below.

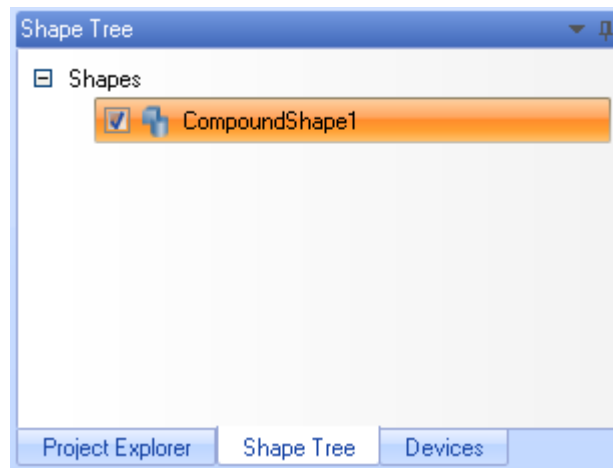



Figure 41 – Compound shape on Shape Tree

9.3.1 Cut

The *Cut*  command gives you the option of cutting a particular overlapped section of the first selected 3D shape from the other selected 3D shape.

You can access this command in the *Boolean Operations* group on the *Modeling* tab.

To cut an overlapped section of an object

1. Place the 3D shapes such that one shape overlaps the other.
2. Select the 3D shape that you want to modify. (Select the Cylinder)
3. Select the other 3D shape that you use to cut. (Ctrl + click the object)
4. After you have selected the two 3D shapes, click the **Cut** button in the *Boolean Operations* group.

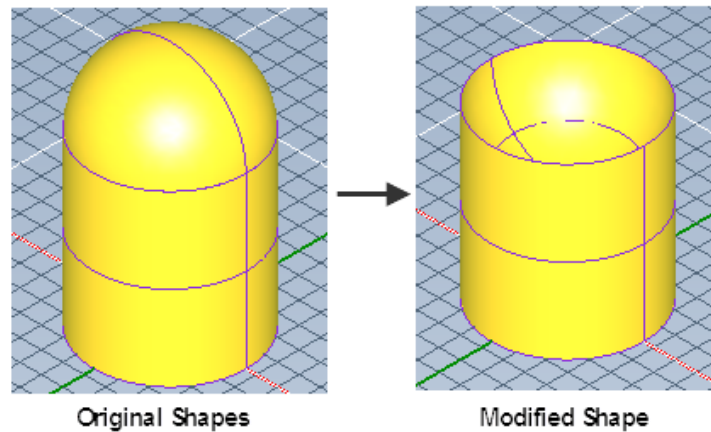



Figure 42 – Cut shape

9.3.2 Fuse

The *Fuse*  command gives you the option of joining two 3D objects together to make a single 3D shape.

You can access the *Fuse* command in the *Boolean Operations* group on the *Modeling* tab.

To fuse two 3D objects

1. Select the two 3D objects you want to fuse.
2. Click on the **Fuse** button in the **Boolean Operations** group.

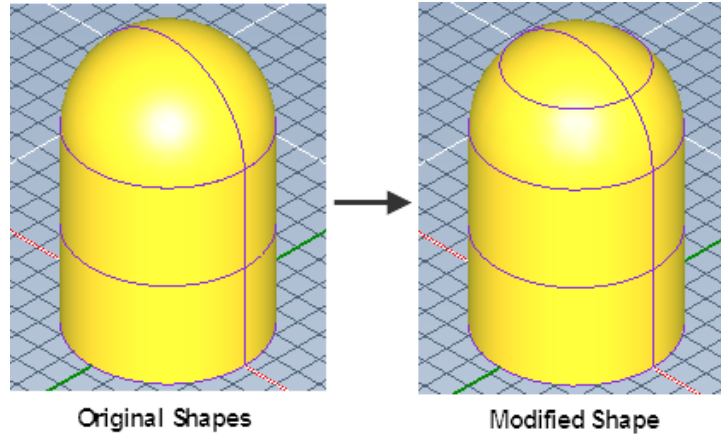



Figure 43 – Fuse shape

9.3.3 Common

The *Common*  command gives you the option to extract the common section of two selected 3D shapes.

You can access the *Common* command in the **Boolean Operations** group.

To extract the common section using the Common operation

1. Select the two 3D shapes.
2. Click the **Common** button in the *Boolean Operations* group.

TIP

ScanMaster™ Designer software allows you to select only two shapes at a time to make a *Boolean Operation*.

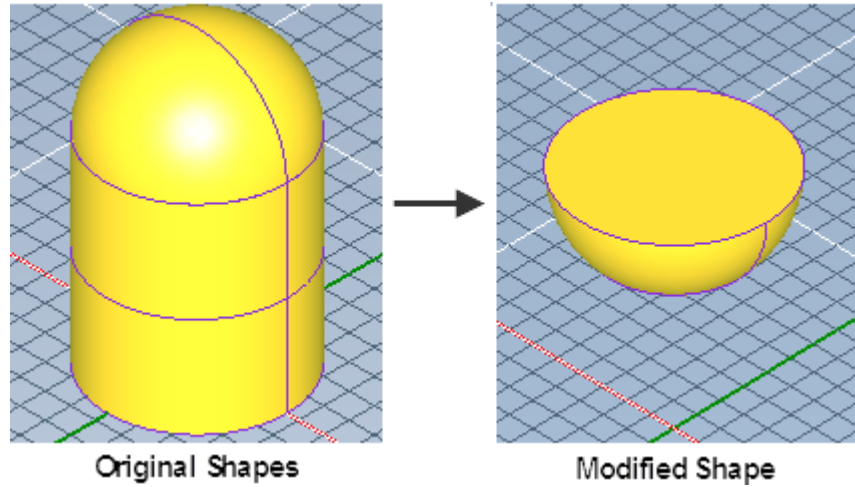

Figure 44 – Extracting the common part of the two 3D shapes

9.4 Solid Operations

You can do certain modifications to the basic 3D models using the options in the *Shape Operations* group on the *Modeling* tab.

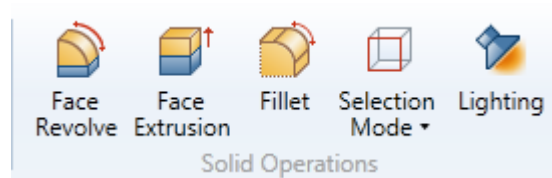

Figure 45 – Solid Operations group

TIP

These functions will form compound shapes in the *Shape Tree* same as in *Boolean Operations*.

9.4.1 Selection Mode

This command in the *Solid Operations* group allows you to specify the selection mode.

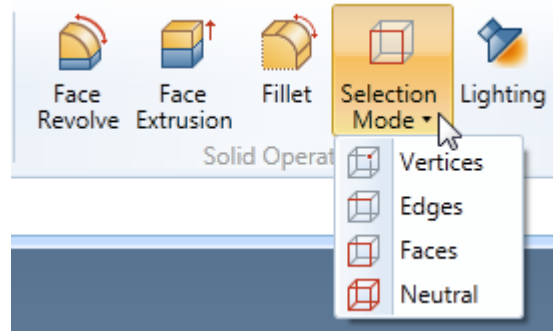

Figure 46 – Selection Mode



TIP

Neutral mode is the default selection mode which enables the selection of whole 3D shapes.

9.4.2 Face Revolve

Face revolving function allows you to revolve a face of a 3D object over an axis. The revolving axis can be defined by specifying the values on the *Standard Axis* tab or on *Arbitrary axis* tab.

To revolve a face of an object:

1. Select the desired 3D object.
2. To change the *Selection Mode* to *Faces* selection mode, click the **Faces** option from the *Selection Mode*  list in the *Shape Operations* group.
3. Select the face you want to revolve.
4. Click on the preferred face of the 3D object.
5. Click the **Face Revolve**  command in the *Shape Operations* group.

You will find the **Revolve** dialog box as you see in the figure below.

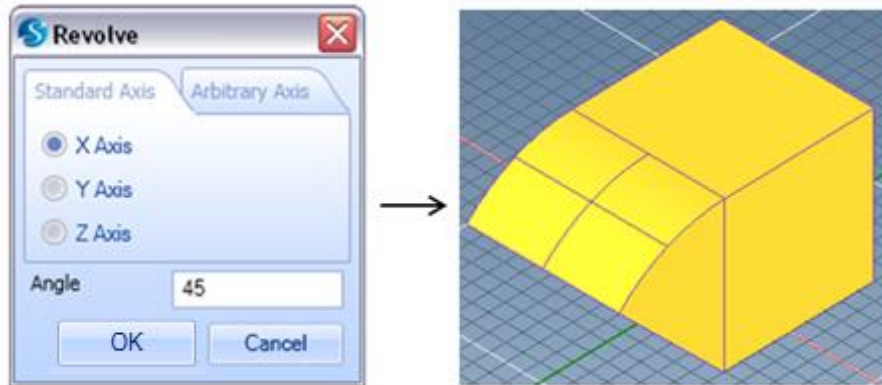



Figure 47 – Face revolved by a standard axis

6. Define the axis that you want to revolve on the **Standard Axis** tab or select the **Arbitrary Axis** to revolve with respect to an arbitrary axis.
7. Select either **Point and Vector** or **Two Points** options and define the respective values of the revolving axis.
8. Define the revolving angle in the **Angle** text box.
9. Click **OK**.

9.4.3 Face Extrusion

This function allows you to change the dimensions of an object by extending a selected face according to a specified extrusion length.

You can access the **Face Extrusion**  command in the *Shape Operations* group on the *Modeling* tab.

To extrude a selected face of an object

1. First change the *Selection Mode* to *Faces* selection mode, click the **Faces** option from the *Selection Mode*  list in the *Shape Operations* group.
2. Select the face you want to extrude.
3. Click the **Face Extrusion** button in the *Shape Operations* group.

4. Click on the face of the object and specify the length to be extruded on the given text box as shown in the figure.

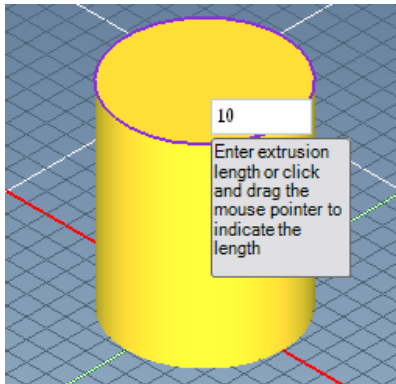

Figure 48 – Define the extrusion length

– OR –

You can also click and drag the mouse pointer on the selected face until you reach the desired length that you need to extrude as you see in the next figure. Click on the canvas after you reach the desired length.

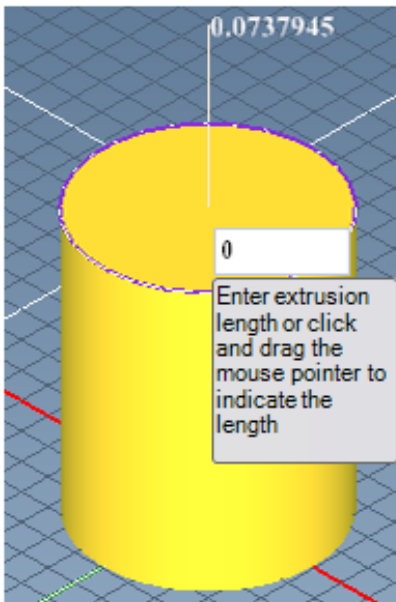

Figure 49 – Drag to the desired extrusion length

9.4.4 Fillet

This function allows you to modify the edges of a selected 3D object.

To fillet a 3D object

1. Change the **Selection Mode** according to your requirements.
2. Select the 3D object on which you want to perform the filleting operation.
3. Click the **Fillet**  command.
4. Specify the fillet **Radius** on the *Fillet* dialog box.



Figure 50 – Fillet window

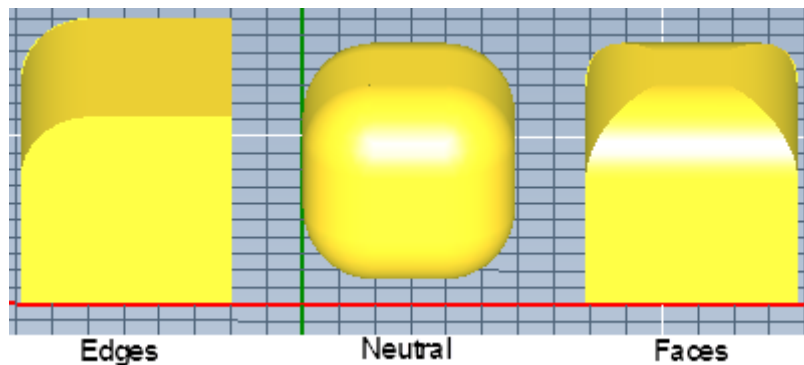

Figure 51 – Fillets on different selection modes

The above figure shows how a *Box* with the dimensions of 12, 12, 12 will be modified according to its different selection modes when the *Fillet* command was used with a *Radius* of 5.

TIP

The *Fillet* function will not be applicable to the *Vertices* selection mode.

9.4.5 Lighting

The *Lighting* command allows you to change the lighting effects of the 3D object on the 3D drawing canvas.

- Click on the **Lighting**  button in the *View* group of the *Home* tab.

The following window will be displayed.



Figure 52 – Lighting window

Ambient Light

Ambient Light  effect illuminates uniform light rays around the object from every direction.

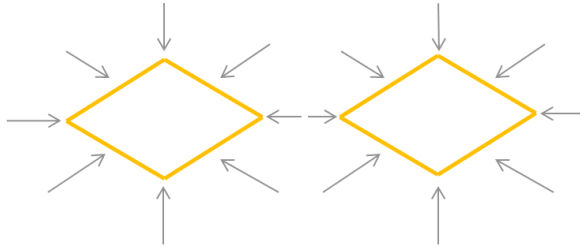

Figure 53 – Illustration of Ambient Light

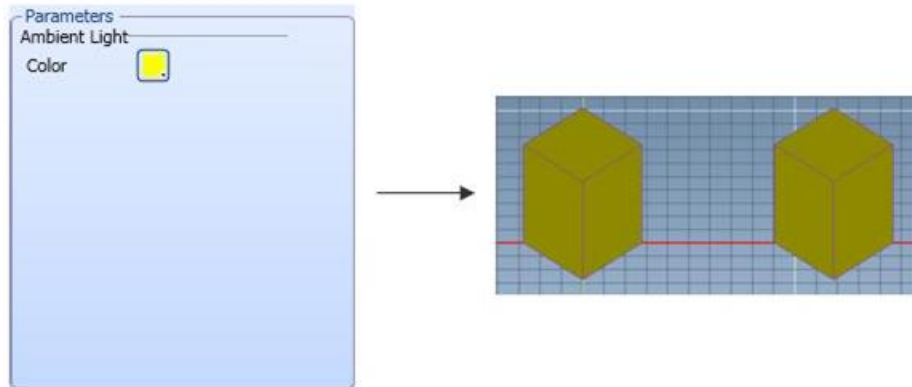



Figure 54 – Ambient Light

TIP

You can select any color of the light from the *Color* option in the *Parameters* group.

Directional Light

Directional Light  emits light rays from a particular defined direction.

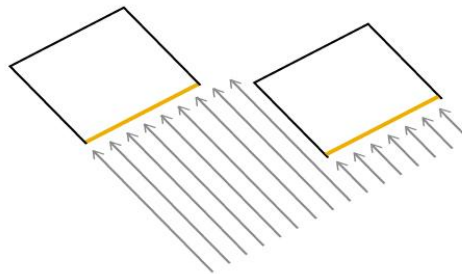

Figure 55 – Illustration of Directional Light

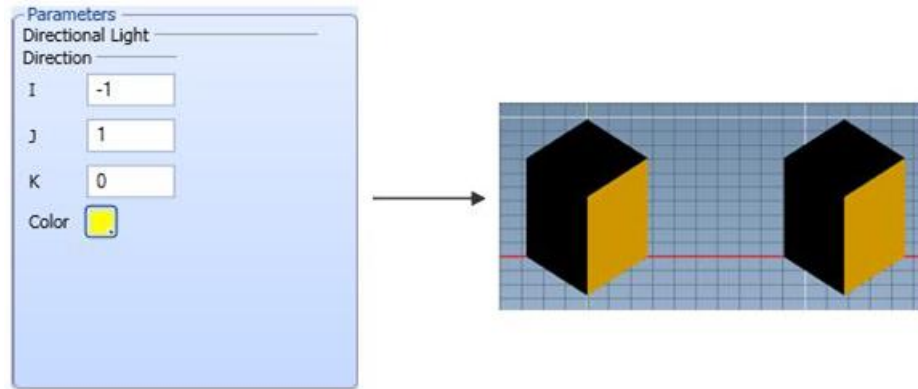

Figure 56 – Directional Light

Spot Light

The **Spot Light** effect spots the light ray on to a particular specified position on the canvas.

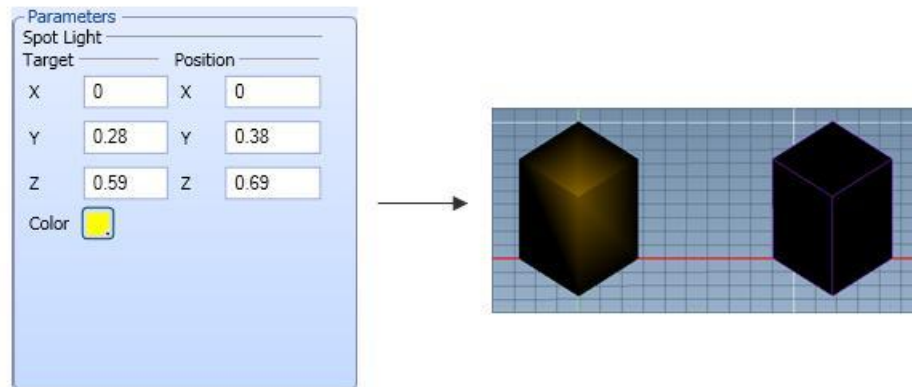

Figure 57 – Spotlight

Target specifies the targeting position.

Position specifies the position of the light.

Point Light

The **Point Light** command enables you to spread light rays towards the drawing canvas from a specified position of the light.

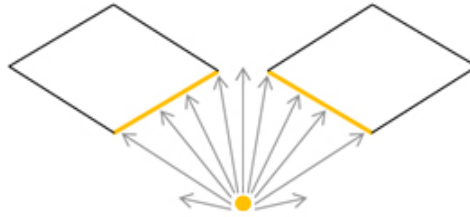

Figure 58 – Illustration of Point Light

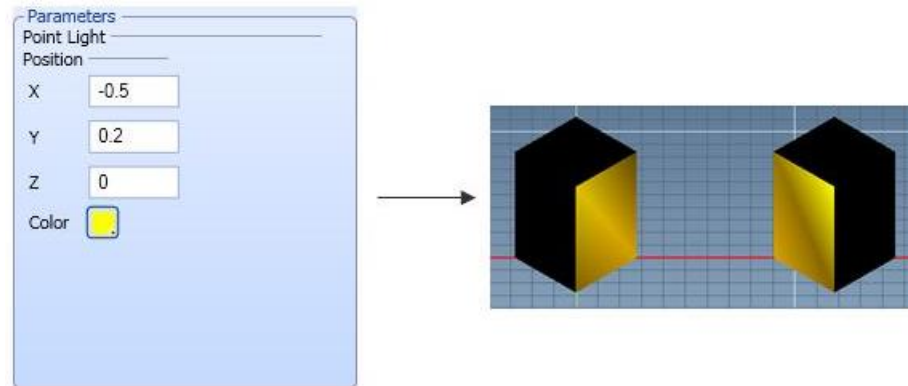



Figure 59 – Point Light

9.4.6 Deleting the light effects

To delete any inserted light effect on the drawing canvas

1. Select the light effect you want to delete from the *Lighting* window.
2. Click on the **Delete Light**  button.

TIP

Select the *Keep default light on* check box on the bottom-left of the window to reset the light effects to the default settings.

10 Process preparation

The final step before you mark your 3D model is the preparation of the 3D process. This chapter guides you on the process of preparing the 3D model for your laser marking.

10.1 Surface Marking process

After you have created the 2D and 3D models you can start working on your 3D marking process. In the ScanMaster™ Designer software the surface marking options are designed to mark 2D models on a non-uniform 3D surface. This software enables you to project or wrap a 2D model on to the 3D model.

TIP

Refer to section [11.1](#) on page [112](#) for more details about the differences between the *Projection* and *Wrapping* features in 3D surface marking.

To start a Surface Marking process

1. Select the 3D model from the *Project Explorer* which you want to process.
2. Click on the **Surface Marking**  button in the **Marking Process** group of the *Project* tab.

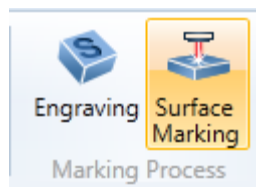

Figure 60 – Surface Marking

You will find the new surface marking process element on the *Project Explorer* once you create a surface marking process.

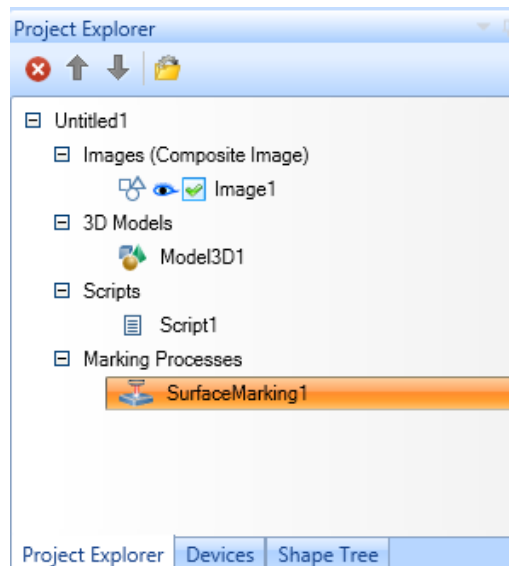

Figure 61 – Surface marking process

3. If you click on the **Surface Marking** button before selecting the 3D model you will find the following *Properties* tab which will direct you to select the desired 3D model.

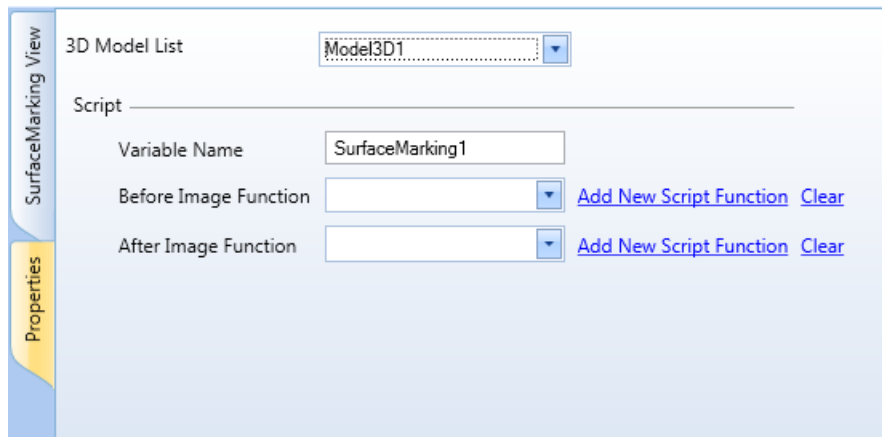

Figure 62 – SurfaceMarking Properties tab

The *Properties* tab allows you to select the appropriate 3D model from the given *3D Model List*.

4. Click on the **3D Model List** drop-down arrow to select the 3D model you want to process.
5. Move to the *Model* tab to proceed.
Then you will see the surface marking 3D model that you selected.

Adding a 2D Image

To add the 2D image to the 3D model on the surface marking process

1. Click on the **Add 2D Image**  button in the *Surface Marking* group of the *SurfaceMarking* tab.

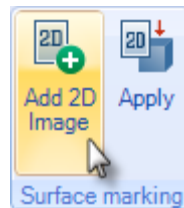

Figure 63 – Add 2D Image button

You will find the following *Add 2D Image* dialog box.

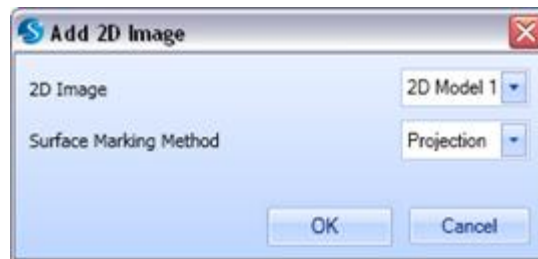

Figure 64 – Add 2D Image

2. Select the appropriate 2D model from the *2D Image* drop-down list.
3. Select the method, either **Projection** or **Wrapping**, you want to map the 2D model from the *Surface Marking Method* drop-down list and click **OK** to confirm and proceed.

10.2 Modify 3D surface marking model

10.2.1 Placement of 2D image

You can apply transformations to the 2D image before you do the marking to obtain the correct position and scaling of the 2D image. ScanMaster™ Designer software allows you to *Move*, *Scale* and *Rotate* the 2D model to adjust and fix it to the 3D model according to your requirements.

1. Click on the **Shape Tree** tab.
2. Select the desired 2D model.

You will be able to find the *Properties* panel in the right-bottom of the window.

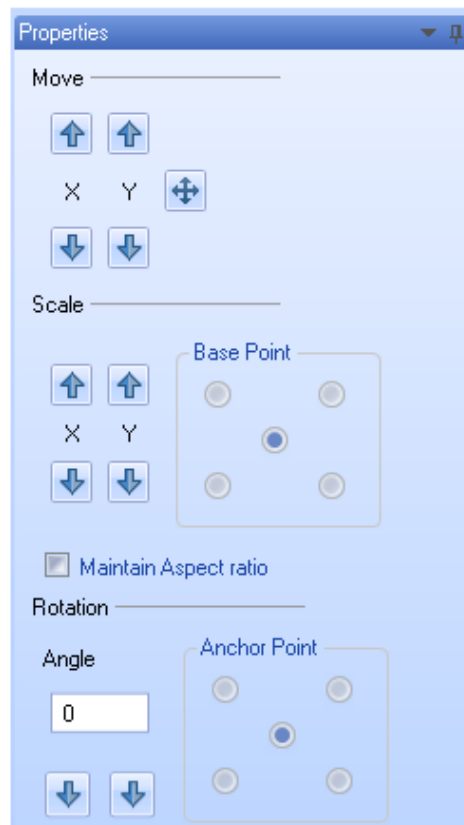



Figure 65 – Properties of 2D Image

Moving 2D Images

You can use the options in the **Move** section of the **Properties** panel to move the 2D image into the desired place.

The arrows as shown in the figure above, allow you to move the 2D image along the **X** and **Y** directions of the 2D image.

You can use the **Move 2D Image**  command to move the 2D. Click and drag the mouse on the 2D image. **Move 2D Image** command functions only before you apply the 2D image to your 3D model.

TIP

The number of units in which the 2D image moves at each click of the arrows will be as configured in the Moving Step option in the Miscellaneous 3D page of the Application Preferences wizard.

Scaling 2D Images

You can use the options in the *Scale* section of the **Properties** panel to scale the 2D image according to your requirements.

The arrows shown in the figure of the **Properties** tab in the previous page allow you to scale the 2D image along the **X** and **Y** directions of the 2D image.

The options in the **Base Point** group allow you to select a desired base point. The selected base point will be kept fixed while you scale the 2D image.

Check the **Maintain Aspect Ratio** option to keep the **X** and **Y** scale factors both similar.

TIP

The number of units in which the 2D image scales at each click of the arrows will be as configured in the Scaling Percentage option in the Miscellaneous 3D page of the Application Preferences wizard.

Rotating 2D Images

You can use the options in the **Rotation** section of the **Properties** panel to rotate the 2D image to the desired angle.

Specify the angle to be rotated on the **Angle** text box and select the desired anchor point from the **Anchor Point** group. The object will be rotated around the selected anchor point.

You can use the **Rotate clockwise** and **Rotate Anticlockwise** buttons to rotate to the 2D image in the desired direction.

10.2.2 Viewing surface marking objects

ScanMaster™ Designer software provides you various viewing options of the surface marking objects.

You can find these options in the *View* group on the *SurfaceMarking* tab.

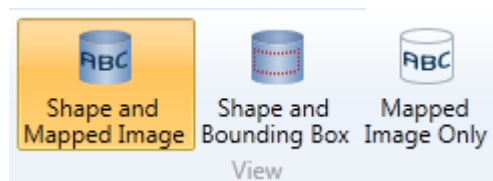



Figure 66 – Viewing surface marking objects

Shape And Mapped Image

The *Shape and Mapped Image*  function allows you to view the 3D model and the mapped 2D image both on the drawing canvas.

You will find this viewing option by default in a surface marking process.

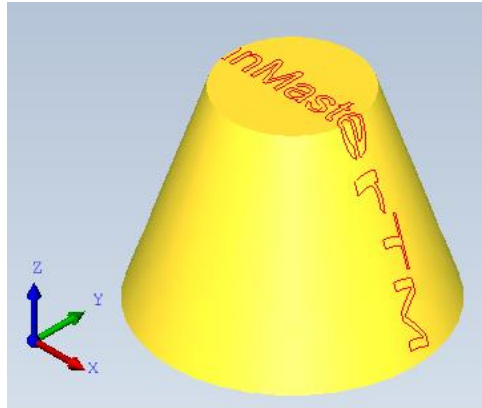



Figure 67 – Shape and Mapped Image

Bounding Box and Shape

The *Bounding Box and Shape*  function allows you to view the bounding box of the mapped 2D image along with the 3D model.

This feature efficiently adjusts a 2D image especially when you handle complex models.

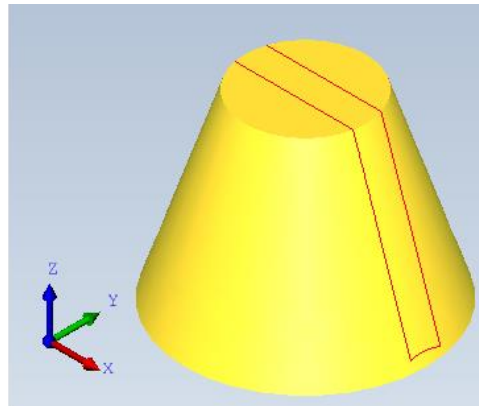



Figure 68 – Shape and Bounding Box

Mapped Image Only

The *Mapped Image Only*  function allows you to view only the mapped image on the drawing canvas.

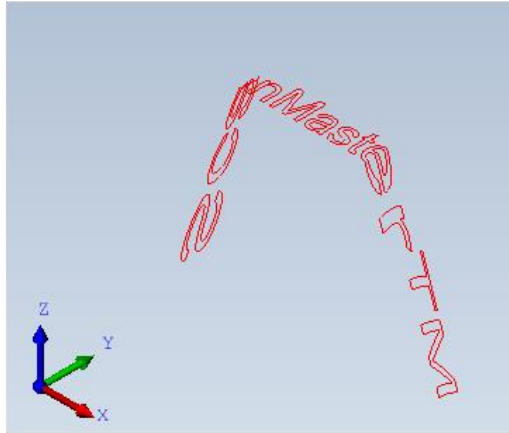

Figure 69 – Mapped Image Only

10.2.3 Running the surface marking project

Once the surface marking process is configured you can proceed to laser marking. The ScanMaster™ Designer provides a very flexible way of managing and controlling the laser marking processes through the script object of the project.

By default, the script will contain a single command to laser mark all the objects in the project tree. To run only the surface marking process, simply delete the default "ScanAll()" command and insert `<ScriptVariableName>.Start()` command to the script. The command starts with the surface marking object name and followed by a ".Start()" command. For example, to start "SurfaceMarking1" object simply insert `SurfaceMarking1.Start()` command to the script.

10.3 Engraving process

Engraving is the process of implementing any desired 3D model by removing material from a 3D object. The process of engraving in ScanMaster™ Designer software enables you to do a laser engraving project.

10.3.1 Create an engraving process

To create an engraving

1. Click the **Engraving**  command in the *Marking Process* group on the *Project* tab.

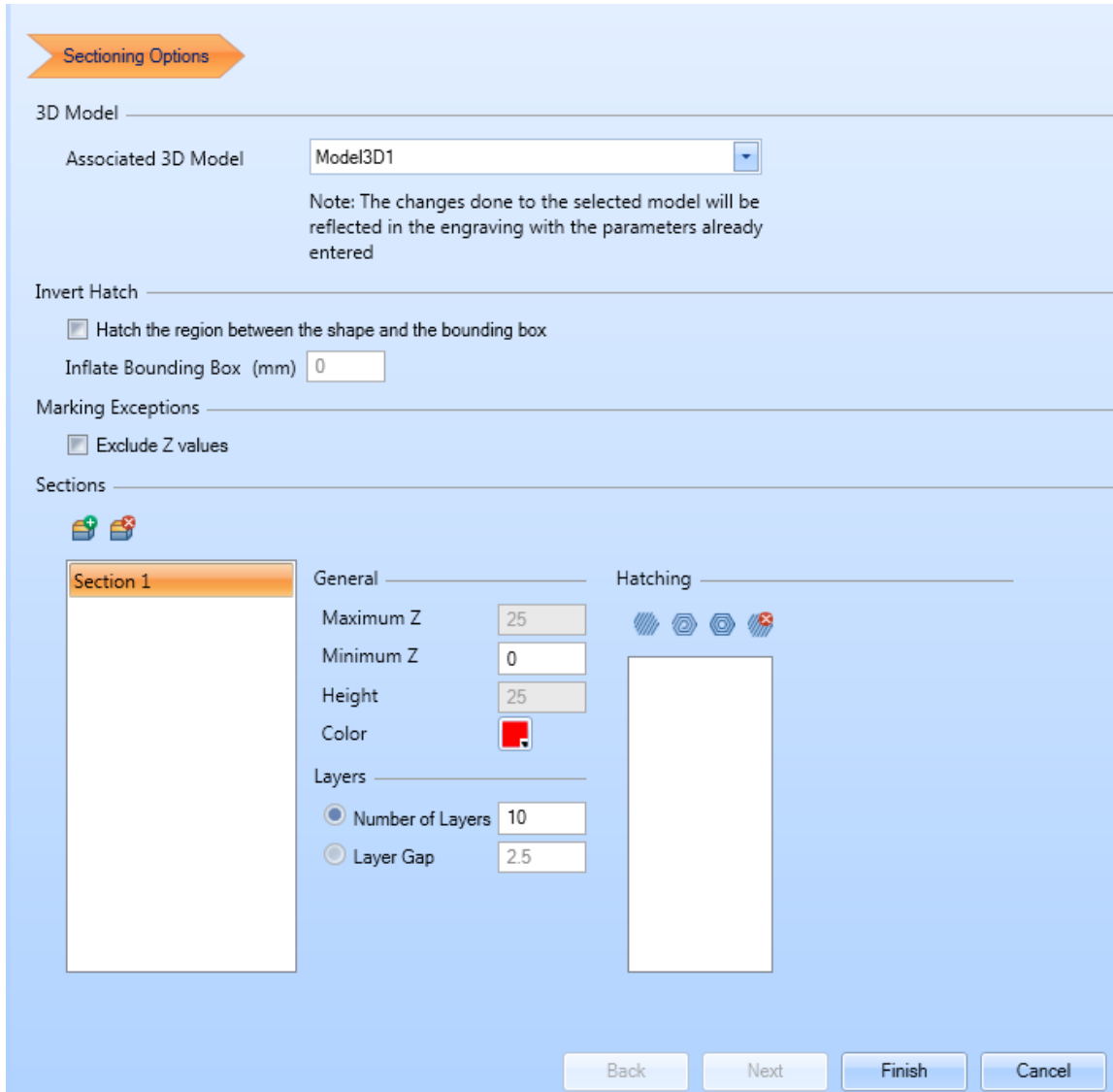

Figure 70 – Add engraving model in wizard

2. Click the **Associated 3D Model** list drop-down arrow to select the 3D model that you want to perform the engraving.
3. Specify the settings of the sections and hatching styles of the engraving process.

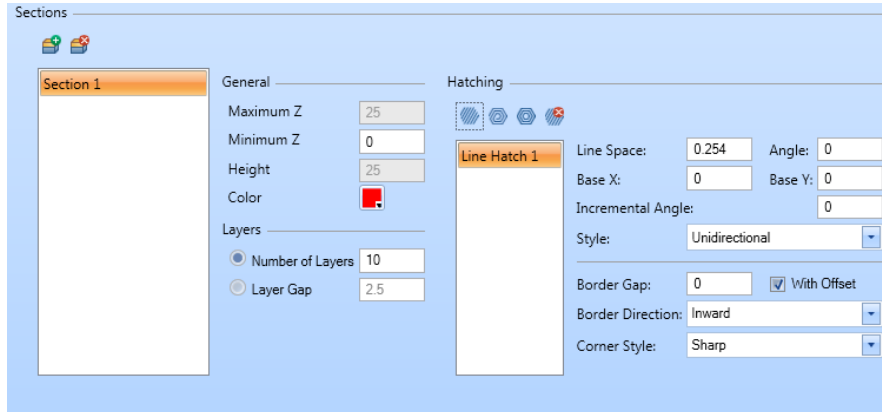

Figure 71 – Sectioning options

The *Sections* group refers to a collection of layers in the engraving 3D model. Initially the 3D model is in a single section. You can split the 3D model into different sections if required. Dividing the 3D model into different sections is useful when there are variations in the properties of the materials, across the cross-section of the 3D model.

The number of layers in a section affects the quality of the output. The number of layers in a section depends on the materials. The harder the material, higher the number of layers should be.

You can specify the properties of the section(s) from the *Sectioning options* wizard.



To add a new Section

- Click on the **Add Section**  button in the **Sections** group.

To change the properties of the Section

1. Specify the **Minimum Z** value of the section.

The *Minimum Z* and *Maximum Z* values define the total Z range of the section by specifying the top-most and bottom-most values.

2. Select either **Number of Layers** or **Layer Gap** to specify the number of layers in which the engraving will be processed.
3. Select a **Color** for different sections so that you can identify the difference of the applied sections.
4. Click the **Delete Section**  button to delete any sections from the process.
5. Add a hatching style from the given *Hatch* styles in the *Hatching* group.
6. Specify the properties of the *Hatching* styles.
7. Click the **Delete Hatch**  button to delete a *Hatch*.
8. Click **Finish**.

TIP

Refer the *ScanMaster™ Designer 2D User Manual, Hatch Operations* in chapter 8 *Shape Operations*, for more details on specifying the *Hatching* Styles.

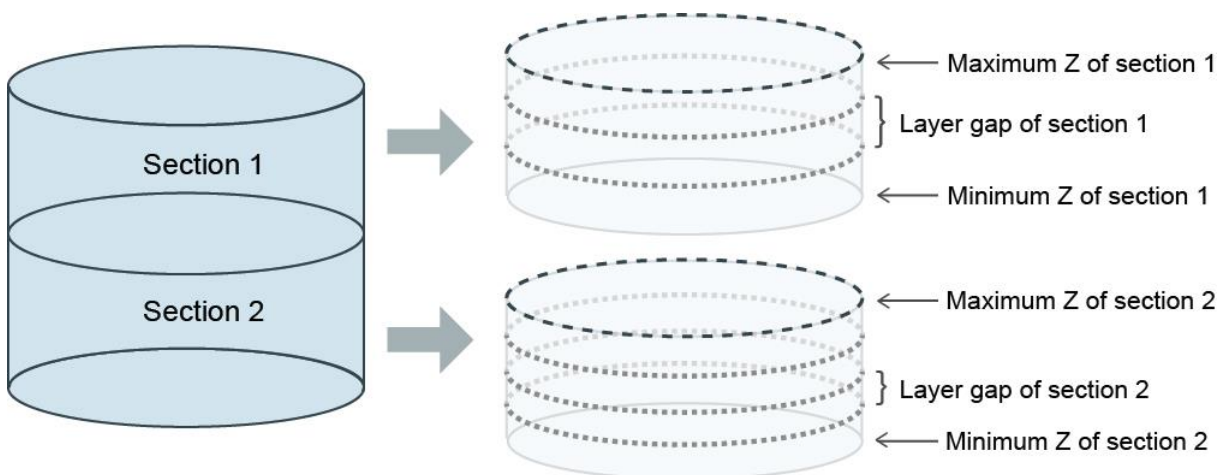

Figure 72 – Sections and Layers of engraving

10.3.2 Modify an engraving

From the *Properties* tab engraving properties can be changed even after creating the Engraving process. The changes made through the *Properties* tab will be added while navigating back to *Engraving View*.

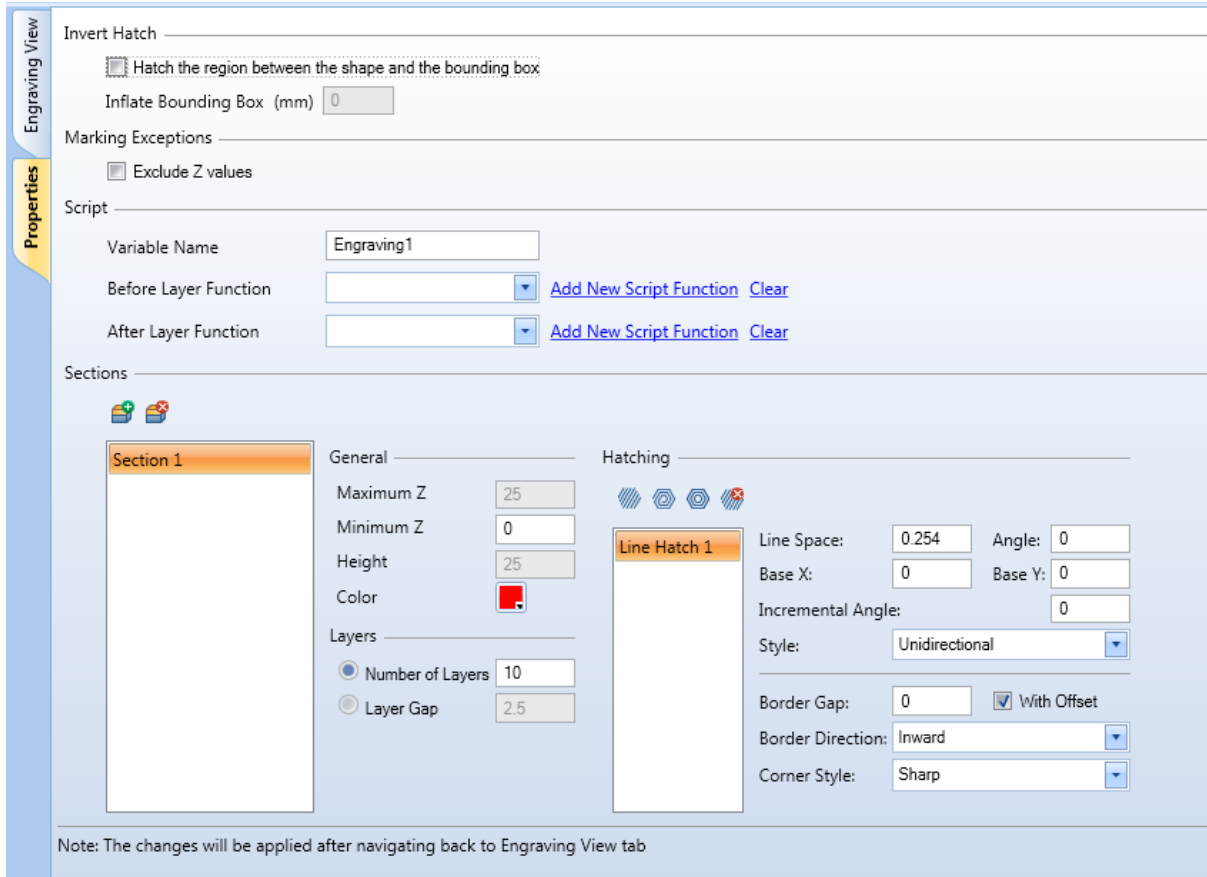

Figure 73 – Engraving Properties

10.3.3 Modify a Section

You can also change the properties of the hatching styles and the colors of the sections.

1. Select the section(s) from the *Engraved Layers* tab.

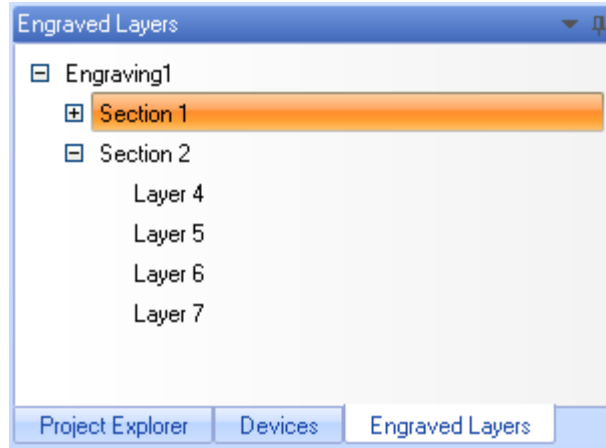

Figure 74 – Engraved Layers tree

2. Edit the properties of the section from the options in the *Properties* panel below the *Engraved Layers*.

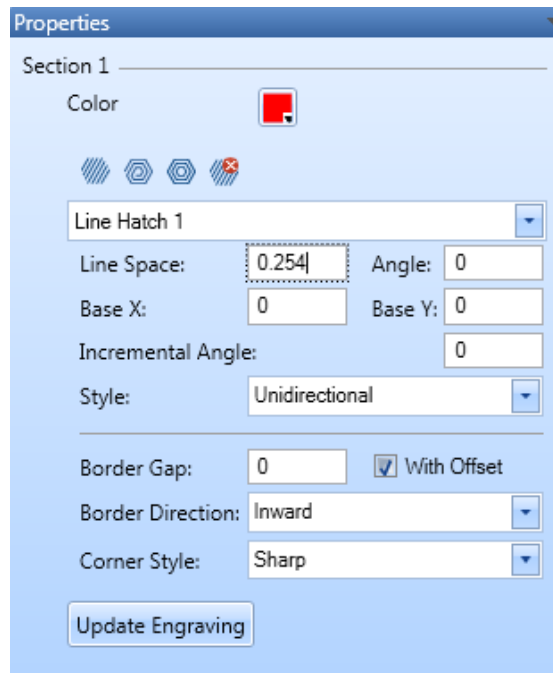



Figure 75 – Section Properties

3. Click on the **Update Engraving** button to confirm the changes.

10.3.4 Viewing engraved objects

The options in the *Viewing Engraved Objects* group on the *Processed Model* tab are featured in a way that enables you to view the engraved objects in three different styles.

The **Boundary Only**  function allows you to view only the boundary of the engraving sections

The **Hatch Only**  function allows you to view only the hatch applied to the 3D shape.

The **Boundary and Hatch**  function allows you to view both the boundary and the hatch of the 3D shape which is to be engraved.

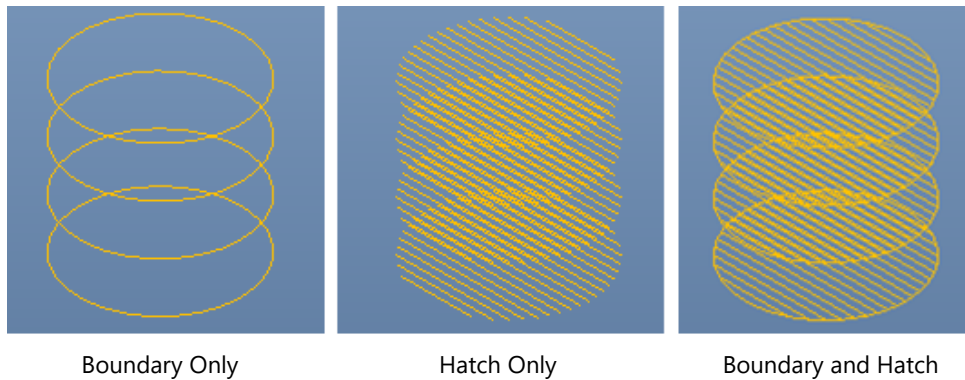



Figure 76 – Viewing boundary and hatch of engraved objects

10.3.5 Engraving Simulations

After you have specified the sections of your engraving process you can preview the engraving process using the options in the *Engraving Simulations* group on the *Processed Model* tab.



Figure 77 – Engraving Simulations group

1. Select the desired section(s) from the *Engraved Layers* tab.
2. Click on the **Start**  button to see the order of the engraving process.
3. Click the **Stop**  to stop the simulation.

The simulation will depend on your selection of the section(s) from the *Engraved layers* tab.

If you want to preview the whole 3D model engraving process, select the engraving process from the *Engraved Layers* tab or select the desired section only to view the simulation of that section only.

10.3.6 Running the engraving project

Once the engraving process is configured you can proceed to laser marking. The ScanMaster™ Designer provides a very flexible way of managing and controlling the laser marking processes through the script object of the project.

By default, the script will contain a single command to laser mark all the objects in the project tree. To run only the engraving process, simply delete the default "ScanAll()" command and insert <ScriptVariableName>.Start() command to the script. The command starts with the engraving object name and followed by a ".Start()" command. For example, to start "Engraving1" object simply insert Engraving1.Start() command to the script.

10.4 Sample Surface Marking

In this section you will be provided an example considering a simple scenario in 3D surface marking process.

Scenario: Create a model of a pipe, project and wrap a text ScanMaster to the internal surface of the pipe.

To try this sample you need to

1. Start ScanMaster™ Designer.
2. Create the 3D Model.
3. Modify the 3D Model.
4. Transform the 3D Model.
5. Create the 2D Model.
6. Change the Viewing Orientation.
7. Process.
8. Edit the 2D Model.

10.4.1 Starting ScanMaster™ Designer

1. Click **Start > Programs > CTI > ScanMaster™ Designer**.
2. Click **New > New 3D Project**.

10.4.2 Create the 3D model

1. To insert a cylinder shape to the drawing canvas, click on the **Cylinder**  command in the *Primitives* group on the *Modeling* tab.
2. Specify the **Radius** and **Height** of the cylinder.
3. Click **OK**.

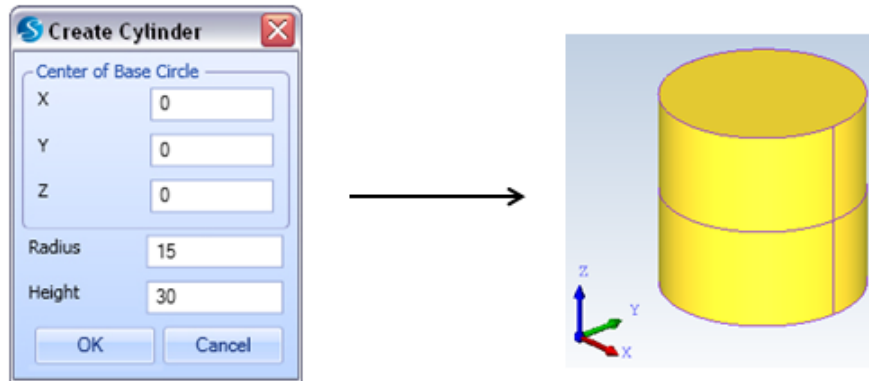

Figure 78 – Cylinder on the canvas

4. To insert a box shape, click on the **Box**  command in the *Primitives* group on the *Modeling* tab.
5. Specify the **Base Point**, **Width**, **Height**, and **Length** of the Box.
6. Click **OK**.

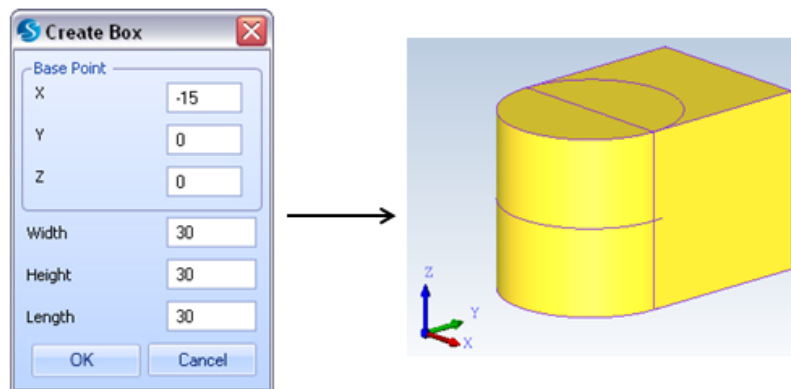



Figure 79 – Cylinder and Box shape on the canvas

10.4.3 Modify the 3D model

1. Select both shapes.

TIP

Select the **Cylinder** shape initially and then select the **Box** shape as you are about to cut the *Cylinder* using the *Box* shape.

2. Click **Cut**  in the *Boolean Operations* group on the *Modeling* tab.

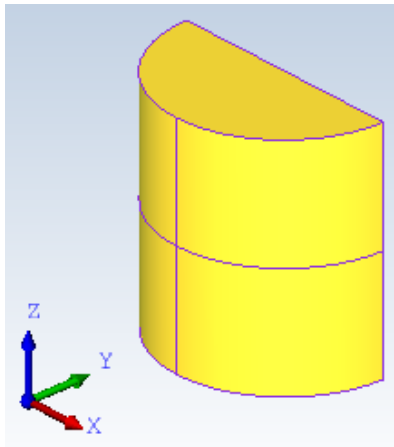



Figure 80 – Cylinder shape cut in half on the canvas

3. Insert another **Cylinder**  shape.
4. Specify the **Radius** and **Height** of the *Cylinder*.
5. Click **OK**.

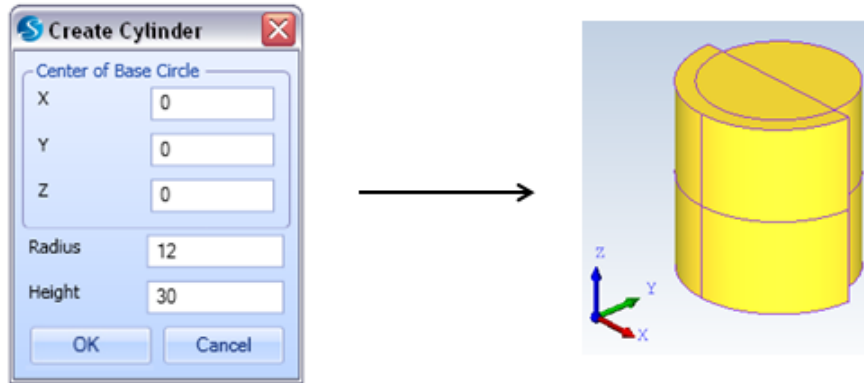



Figure 81 – Half Cylinder and Cylinder shape on the canvas

6. Select both shapes.

7. Click **Cut**  in the *Boolean Operations* group on the *Modeling* tab.

The result will be as shown in the figure below.

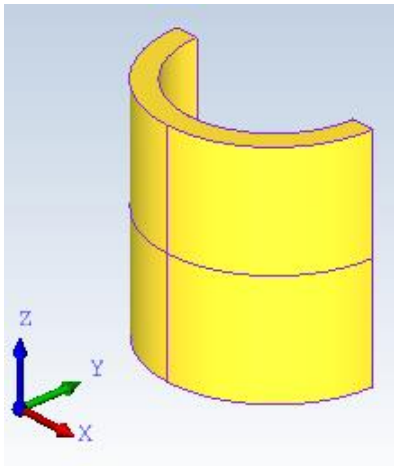

Figure 82 – Half Cylinder cut to half pipe shape on the canvas

10.4.4 Transform the 3D model

Rotate

1. Select the 3D model.
2. Click on the **Rotate** option in the *Transformations* group on the *Modeling* tab.

3. Specify the **Standard Axis** and the **Angle** to be rotated.

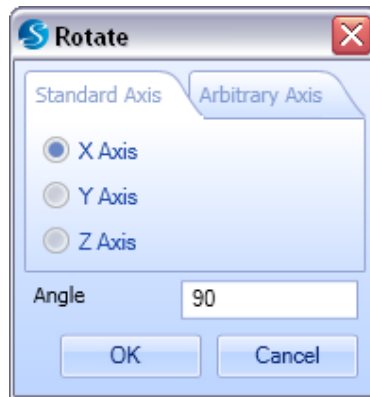



Figure 83 – Rotating parameters

Move to Origin

1. Click the **Move to Origin**  button in the *Transformations* group.
2. Select the **Center of Bottom**  option from the list.

10.4.5 Create the 2D image

1. Click the 2D image that is already added to the project by default.
2. Click the **Insert Text**  button.

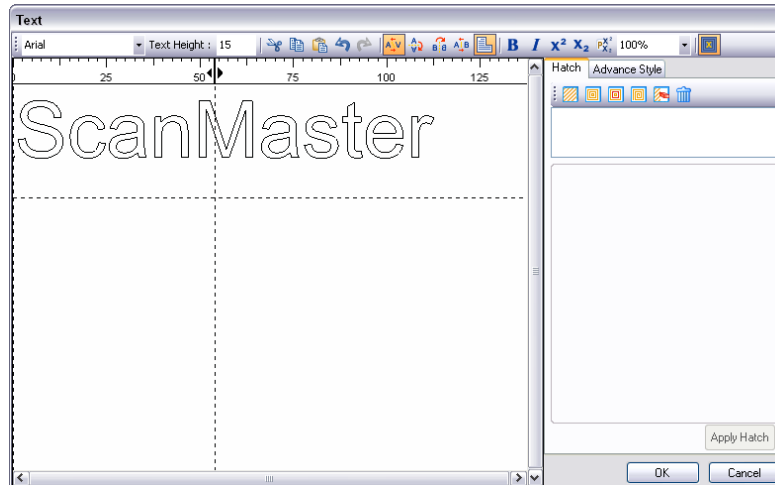

Figure 84 – Text editor

3. Specify the **Text Height** and press **Enter**.
4. Type ScanMaster as the text.
5. Click **OK**.



Figure 85 – 2D image

10.4.6 Change the viewing orientation

Before you start the process change the viewing orientation to *Top* to make your work much easier.

1. Click **View Orientation**  button in the *View* group.
2. Select **Top**  from the *View Orientation* list.

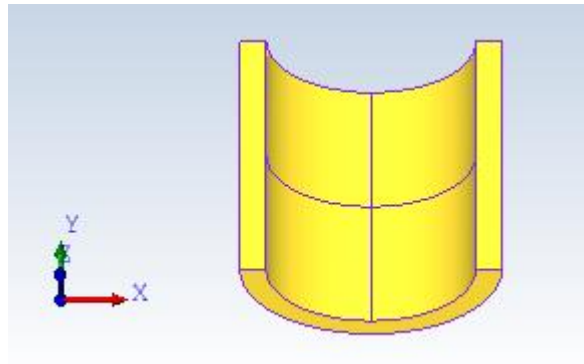

Figure 86 – Top orientation

10.4.7 Process

To do a Projection



1. Click the **Surface Marking**  button in the *Process* group on the *Home* tab.
2. Select the **Surface Marking1** process from the *Project Explorer* tab.
3. Click the **Add 2D Image**  button in the *Surface Marking* group on the *Processed Model* tab.



Figure 87 – Add 2D Image

4. Select the **2D Model 1**.
5. Select **Projection** from the *Surface Marking Method* drop-down menu.
6. Click **OK**.

10.4.8 Edit the 2D image

1. Select the **Shape Tree** tab.
2. Select the **2D Model 1**.
3. Select the **Properties** tab of the *Shape Tree*.
4. Check the **Maintain Aspect Ratio** check box.
5. **Scale** down the 2D image across the **X** axis to adjust according to the 3D model.
6. Click on the **Apply**  button to project the 2D image to the 3D model.

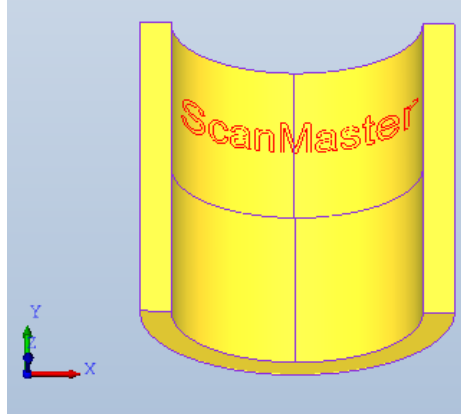



Figure 88 – Apply Projection

To do a Wrapping

1. Click **Add 2D Image**  button in the *Surface Marking* group on the *Processed Model* tab.
2. Select the **2D Model 1**.
3. Select **Wrapping** from the **Surface Marking Method** drop-down menu.
4. Select the desired face of the 3D model where you need to wrap the 2D image.

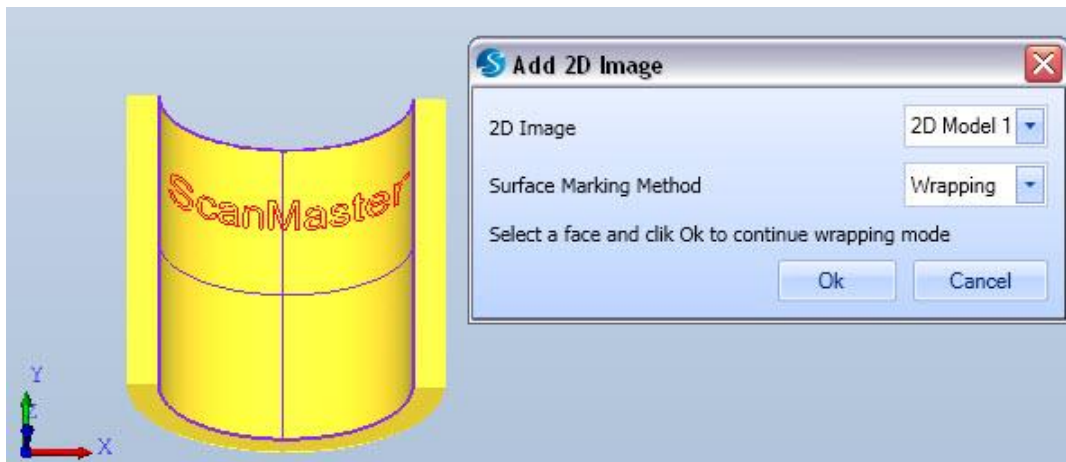



Figure 89 – Select the desired face

5. Click **Ok**.

6. Adjust using the **Scale** and **Move** functions in the *Properties* panel.
7. Click **Apply**  button to wrap the 2D image to the 3D model.

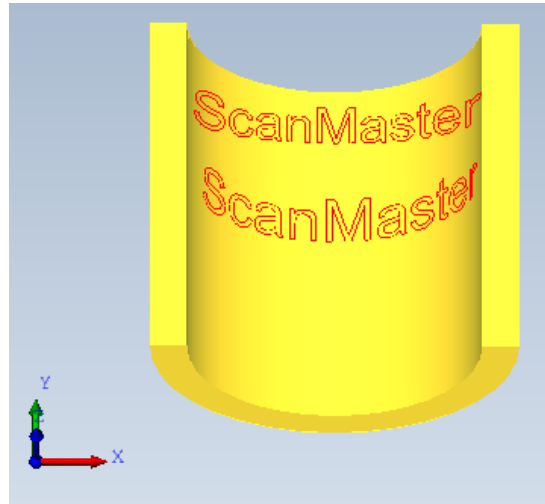

Figure 90 – Projection and Wrapping

10.5 Sample engraving

In this section you will find a sample engraving process performed using ScanMaster™ Designer software. The expected output of this sample scenario is to create a physical logo using a work piece of two metals including aluminum and brass.



Figure 91 – Predesigned engraving model

Assume that you have a cylindrical work piece with a combination of two metal layers as aluminum and brass. To create this physical logo, you need to remove the unnecessary sections by engraving.

For you to get this output you must create an appropriate mold that tells the system which parts to be engraved and which parts are not to be engraved. The mold should consist only the sections that needs to be engraved. A predesigned 3D model which looks exactly as the actual output will be required to extract some sections from the mold which are not supposed to be engraved.

The ultimate result of this process should remain a “S” shape on the aluminum layers and make two screw holes in the brass layer.

Refer the following sections to check how this sample engraving can be performed using ScanMaster Designer 3D Extension.

To try this sample, you need to

1. Open ScanMaster™ Designer 3D project.
2. Create the mold.

3. Modify the model.
4. Prepare the engraving process.
5. Check the engraving simulation.

10.5.1 Open ScanMaster™ Designer 3D project

1. Click **Start > Programs > CTI > ScanMaster™ Designer**
2. Click **New**.



TIP

Check section [7.1](#) on page [46](#) to revise the facts that you should keep in mind when handling a 3D project using ScanMaster™ Designer.

10.5.2 Create the mold

The aim of creating this mold is to extract an appropriate virtual model that allows you to engrave the desired structure on the original material.

Import the predesigned 3D model

1. Go to **Project** Ribbon tab.
2. Select **3D model**  button from the **Import**  drop down button.

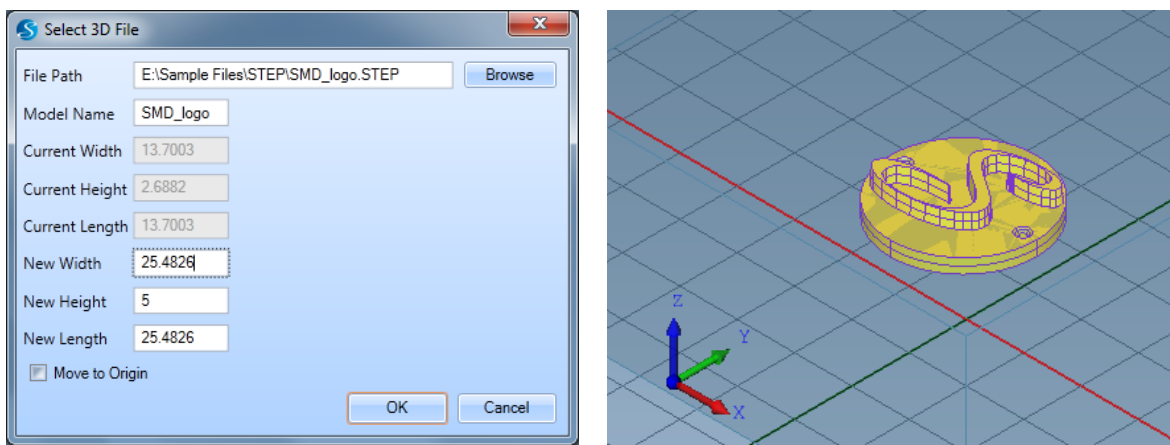



Figure 92 – Imported 3D model

3. Click the **Move to Origin** > **Center of Bottom** option on the *Transformations* panel if required.

To insert a cylinder

1. Insert a **Cylinder**  from the *Basic* group on the *Home* tab.
2. Define the **Radius** and **Height** as 12.6 and 5.

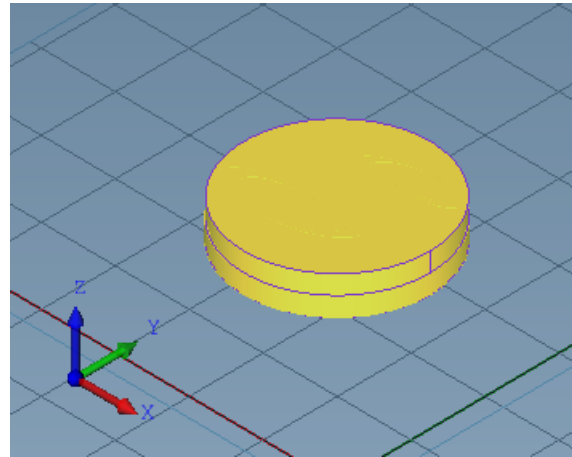
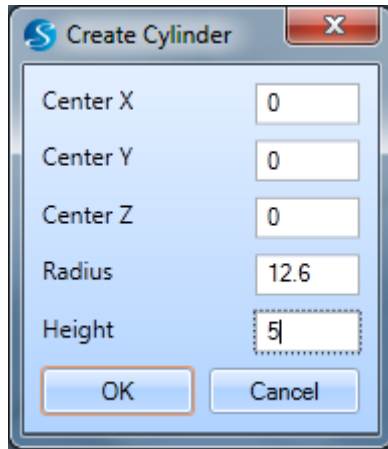



Figure 93 – Inserted Cylinder

10.5.3 Modify the mold

Make sure that you have moved both the models to the origin of the drawing canvas.

TIP

The cylinder shape is inserted to the origin of the drawing canvas by default and the imported model should be moved to the origin. Both models will be placed in the same position of the canvas to perform the *Boolean Operation*.

1. Select the two models. First select the **Cylinder** and then the imported 3D model.
2. Click **Cut**  command in the *Boolean Operations* group on the *Modeling* tab. The figure below shows the mold that was created.

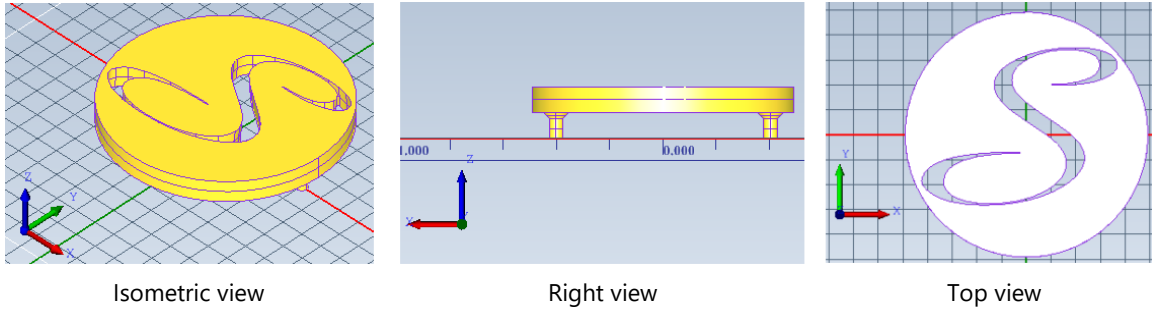



Figure 94 – Modified image in different view orientations

10.5.4 Prepare for the engraving process

The next step in this scenario is to prepare the model for the engraving process.

1. Click the **Engraving**  command in the *Marking Process* group on the *Project* tab.

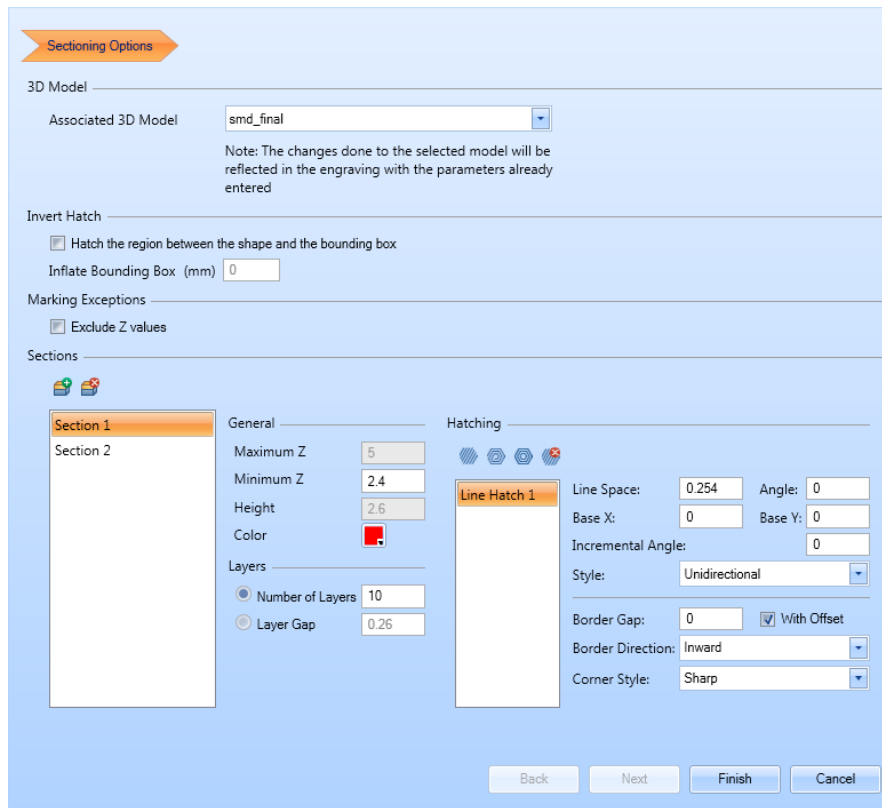

Figure 95 – Specifications of Section 1

- Specify the **Minimum Z** of *Section 1* as 2.4.

TIP

The height of the sections depends on the heights of the two materials. Measure the height of the original materials and specify the heights of the sections respectively.

- Define appropriate number of layers to each section depending on the materials of the sections.
- Insert a desired type of hatch for both sections from the given hatching styles.
- Click **Finish**.

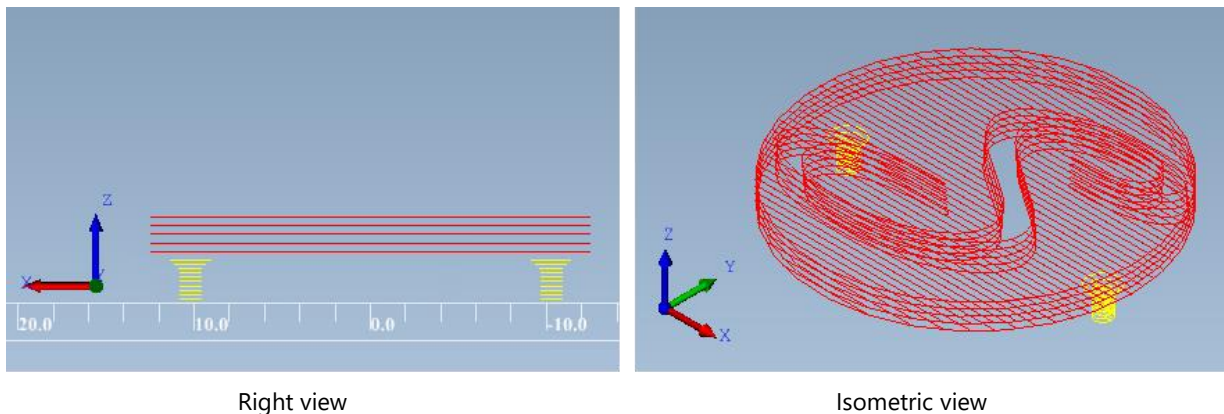



Figure 96 – Engraving Layers and Sections of the 3D model

10.5.5 Check the engraving simulation

After you specified the parameters for your engraving process you can use the *Engraving Simulation* commands to view the simulation and adjust if needed.

- Click **Start**  command of the *Processed Model* > *Engraving Simulation* panel to view the engraving simulation.
- Click **Stop**  command to stop the simulation.

11 Appendix

11.1 Surface Marking

Surface marking is one of the available 3D scanning processes. *Surface Marking* in 3D scanning projects refers to mapping a 2D image to a 3D surface there by obtaining a quality 3D marking. ScanMaster™ Designer provides you features that enable you to do surface markings in two different styles:

- Projection
- Wrapping

Multiple 2D images can be projected or wrapped to a 3D model in different viewpoints according to the users requirements.

11.1.1 Projection

Projection is used to project a 2D image to a 3D surface. Projection in 3D surface marking refers to mapping a 2D image to a 3D surface in a way that the resulting 3D image will be undistorted when viewing in the direction of the projection. If you view the projected image in a different direction, you will see that the edges of the image have extended beyond the border or line.

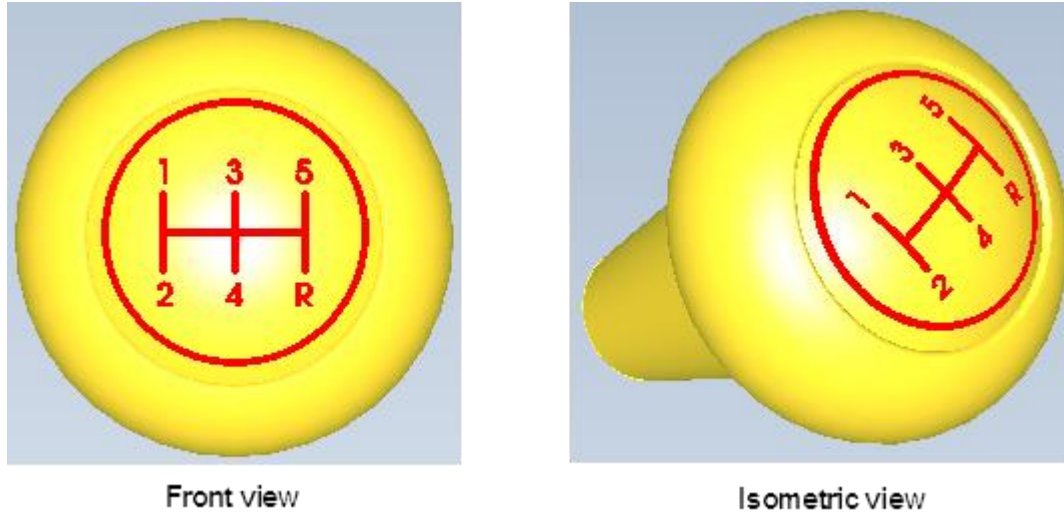

Figure 97 – Projection

11.1.2 Wrapping

This technology is used to wrap a 2D image to a 3D surface. Wrapping in 3D surface marking refers to mapping a 2D image in a way that the resulting image will have the minimum distortion locally when viewed in any direction.



Figure 98 – Wrapping

11.2 Specifying the axes

Most of the functions in ScanMaster™ Designer allow you to select the **Standard Axis** or the **Arbitrary Axis**. This section will help you to understand the difference between the standard axes and the arbitrary axes.

11.2.1 Standard Axis

The standard axes are defined by the **X**, **Y** and **Z** values as you see in the figure below. These axes refer to the normal axes to define the position on the drawing canvas.

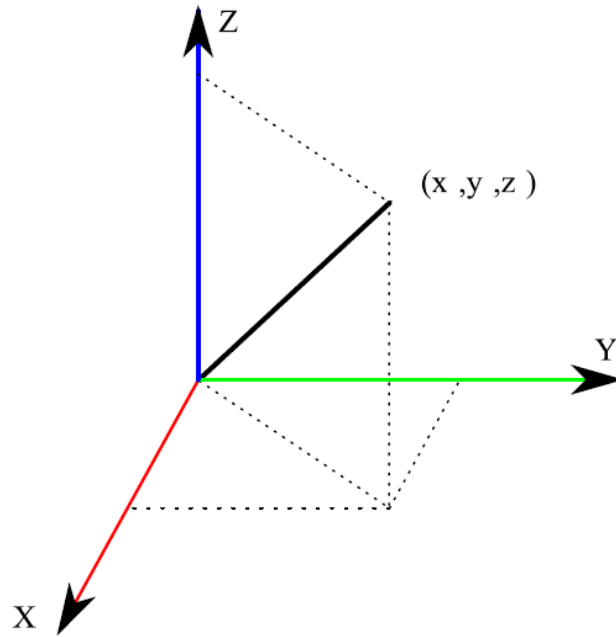

Figure 99 – Standard Axis

11.2.2 Arbitrary Axis

To define the *Arbitrary Axis*, you can specify in two ways. You specify either the **Point and Vector** or the **Two Points**.

Point and Vector can be used in situations where you want to specify a position and the vector or the direction from that point onwards.

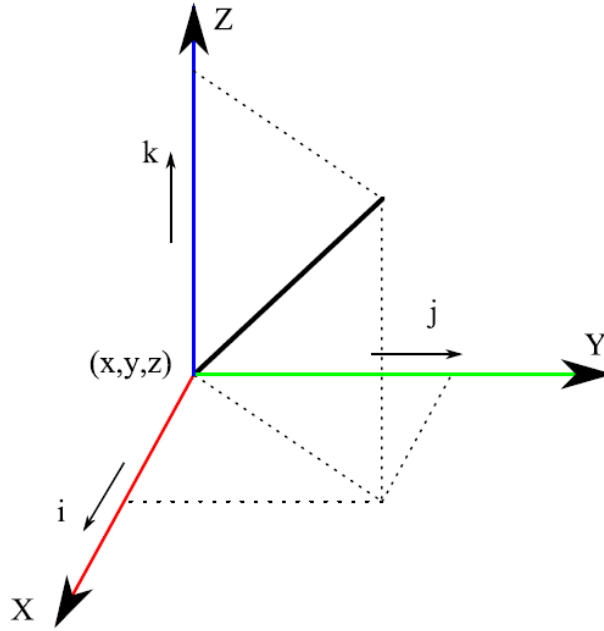

Figure 100 – Arbitrary Axis – Point and Vector

Two Points can be used in situations where you want to specify two points to define a direction across the defined two points which includes the starting points and the end points on the drawing canvas.

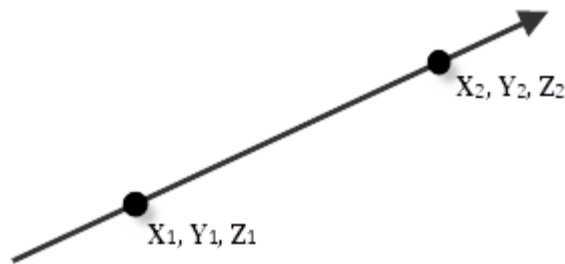

Figure 101 - Arbitrary Axis - Two Points



Novanta Corporation

125 Middlesex Turnpike
Bedford, MA 01730, USA

Phone: +1-781-266-5700

Email: Photonics@Novanta.com

Website: www.NovantaPhotonics.com

ScanMaster Designer 3D Extensions

User Manual

1040-0009 Rev D

© 2024, Novanta Corporation. All rights reserved.