

Firestar v Series air cooled laser & Flyer 3D System Quick Start Guide

SYNRAD

Important Note:



See the Flyer 3D Marking Head and Firestar v Series Laser Operators Manual for complete installation details and instructions. A PDF version is available Online at: http://www.synrad.com/Manuals/manuals_laser.htm.

Read all ⚠️ Danger, ⚠️ Warning, ⚠️ Caution terms, symbols, and instructions located in the (Laser Safety Hazard information) sections in the Flyer 3D Marking Head and Firestar v Series Laser Operation Manuals.

Marking Head Unpacking:

Attention:



For complete details, refer to the Getting Started (System Inventory and Mounting) Sections in the Firestar v series and Flyer 3D Marking Head Operator's Manual.

1. Lift the Flyer 3D Marking Head out of the box only by the middle; **do not use housing, coolant fittings, or anything else on the sides to lift.**



Correct



- 1.1 Lifting the **Marking Head** correctly by holding in the middle.



Caution



- 1.2 Avoid mis-alignment risk. **Do not** use housing fitting or fan (as shown) or anything on the side to lift.

Firestar v Series air cooled laser & Flyer 3D System Quick Start Guide

SYNRAD

2. Locate the shipping **components for the Marking Head** at the bottom of the box **under** the Marking Head.

2.1 Remove the marking head from the box.



2.2. Retrieve the **components from the box**.



3. Don't forget to **save all shipping container(s) and inserts** for use when shipping or relocating either the laser or the marking head to another location. Packaging is specially designed to protect your laser.

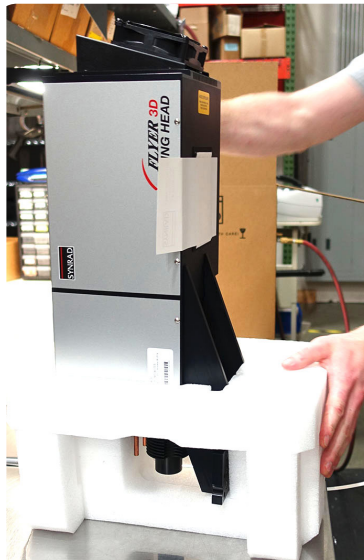

Remove protective cover after final mounting.

3.1. Remove and **retain** the marking head foam.

Firestar v Series air cooled laser & Flyer 3D System Quick Start Guide

SYNRAD

Laser Unpacking:

4. **Unseat** the wiring by **sliding** the harness out of the notch, then down and out of the foam as shown above.

4.1. **Locate the wire harness in side one of the foam end caps.**



4.2. **Push the wire harness through the notch in the foam.**

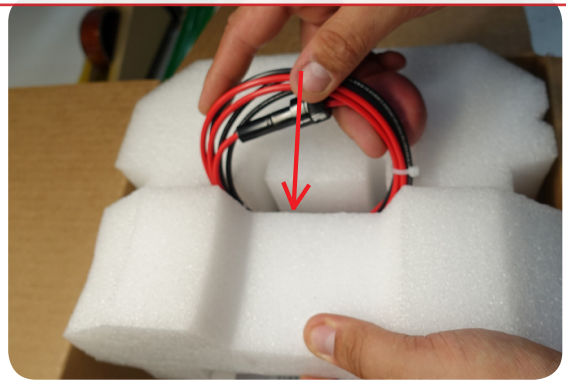

5. **Locate the mounting hardware kit** at the bottom of the box **under** the laser.

5.1 **Correct wire harness** placement for **lifting** the laser out of the box.



5.2 **Correct hand and hand** placement for **lifting** the laser out of the box.



Important Note:



Caution! Unpacking the wire harness incorrectly can damage the laser.

Keep All Foam and Packaging, you will need to re-use it when moving your laser. Refer to this guide and the Getting Started/Technical Reference chapters in the laser's Operation Manual when re-packaging for shipping and/or relocation.

Caution! When packing the laser for relocation or shipment, nothing can be on the sides of the laser at any time as damage will occur. The skin on the sides of the laser is fragile! All box components must be stowed under the laser.

The wire harness will be damaged in shipping if not re-packaged as shown above.

Firestar v Series air cooled laser & Flyer 3D System Quick Start Guide

SYNRAD

Laser Unpacking (Models with ports):

6. When unpacking the laser, make sure to **lift the port end** when seating or unseating the laser into or out of the foam.

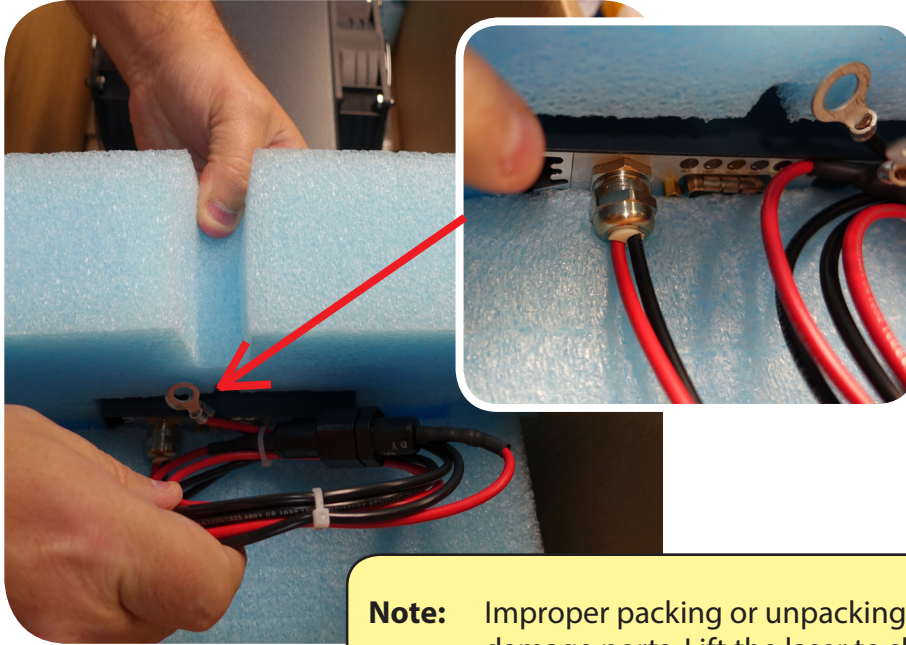

Note: Improper packing or unpacking can damage ports. Lift the laser to slide the foam off.



- 6.1 Gently remove the foam out from under any ports sticking out of the back end of the laser. Take care not to pull the wire when seating or un-seating the foam.

Firestar v Series air cooled laser & Flyer 3D System Quick Start Guide

SYNRAD

Mounting:

7. Support the **Laser** by the **bottom plate-Avoid** carrying by the feet.

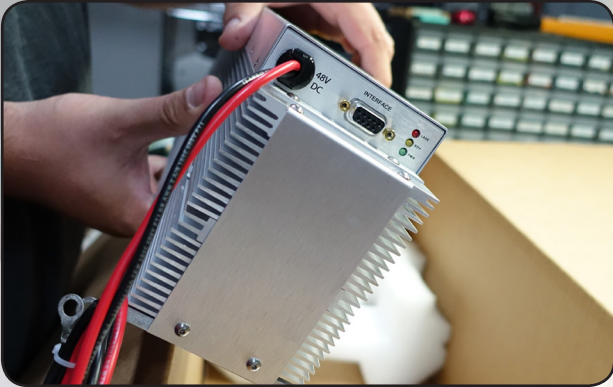

7.1 Do not **handling the laser by the feet!** Doing so can knock the laser out of alignment.

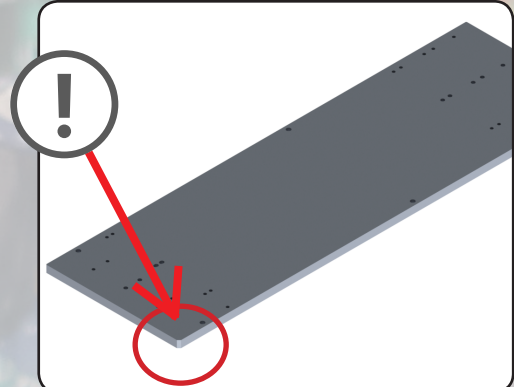

7.2 **Very important! Otherwise, re-work required** because the head will be mounted incorrectly!

8. Remove the **rail** from the packaging. Ensure the notch is facing down and to the left.

Insert a block to **support the Marking Head** before mounting.



9.1 Place the Marking Head on the rail as shown, a block may be used to support the marking head until it is mounted to the rail.

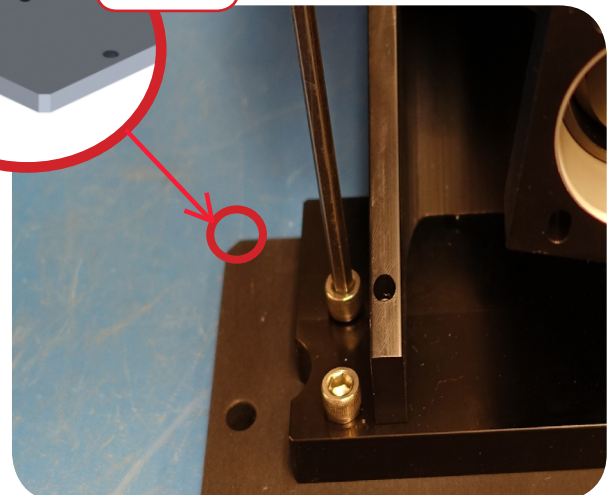
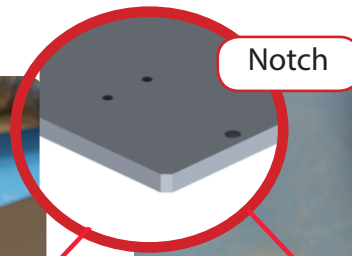

10.1 Attach the Marking Head securely to the rail with the four Allen screws.

9. When attaching the Marking Head to the Laser, **make sure the notch is as shown in figures above before going on to the next step.**

10. Locate the **Mounting Hardware Kit** () Marking Head Safety tube, clamp, and Allen screws.

Firestar v Series air cooled laser & Flyer 3D System Quick Start Guide

SYNRAD

Mounting:

Attention: Remove the laser aperture self-adhesive film before mounting to the rail. Don't tighten the Allen screws on the clamp till the laser is mounted to the rail.

11. Before mounting the laser to the rail, ensure the **aperture seal is removed**, slide the **tube onto the Marking Head first**, then put the **clamp** onto the **tube** as shown in the figure above (**don't tighten the clamp's Allen screws affixing the tube to the laser until after the laser is mounted to the rail**).

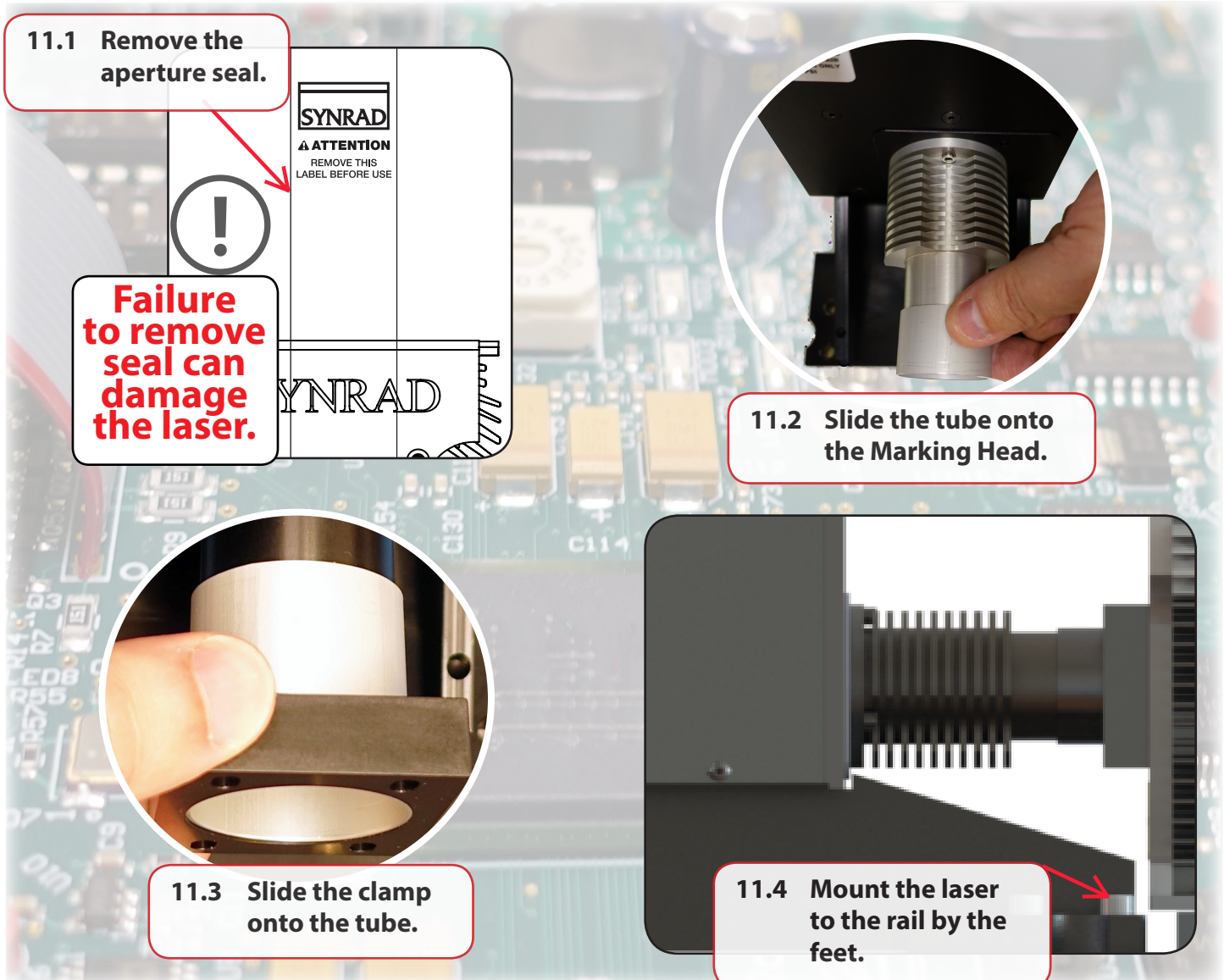

Firestar v Series air cooled laser & Flyer 3D System Quick Start Guide

SYNRAD

Mounting:

12. Finger tighten the clamp to the **Laser** first, then follow with an Allen Wrench as seen in the figure below.

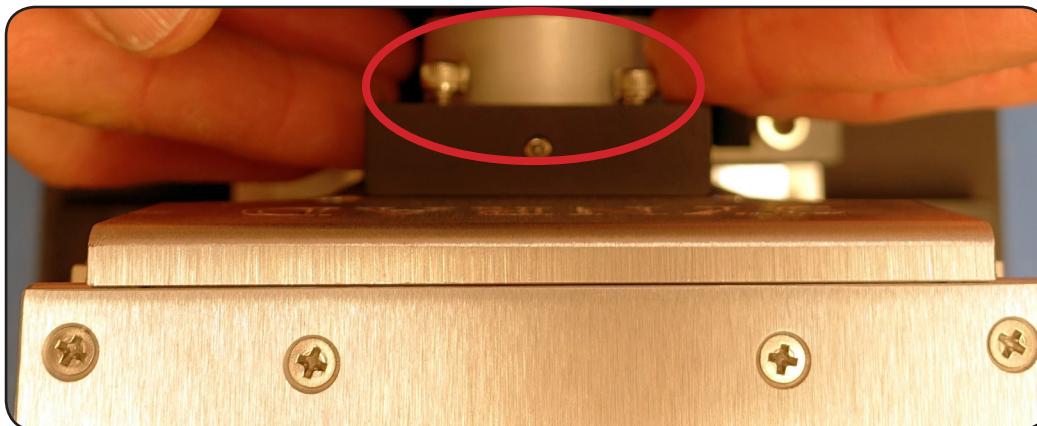

12.1 Finger tighten the clamp to the laser.

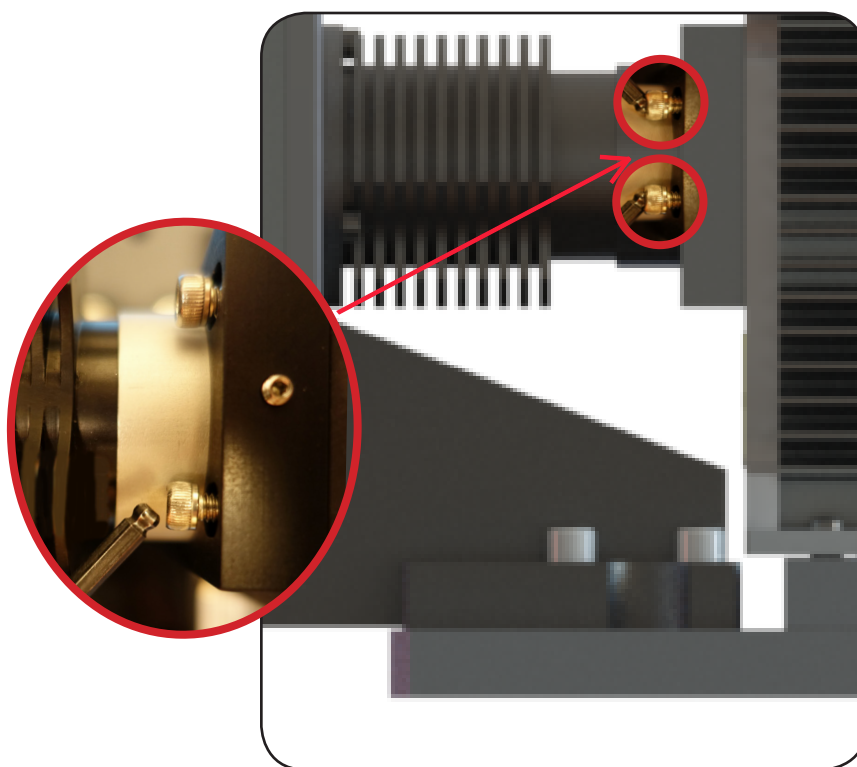

12.2 Follow up with the Allen wrench.

Firestar v Series air cooled laser & Flyer 3D System Quick Start Guide

SYNRAD

Mounting:

13. Marking Head & v series fan cooled laser mounted on rail.

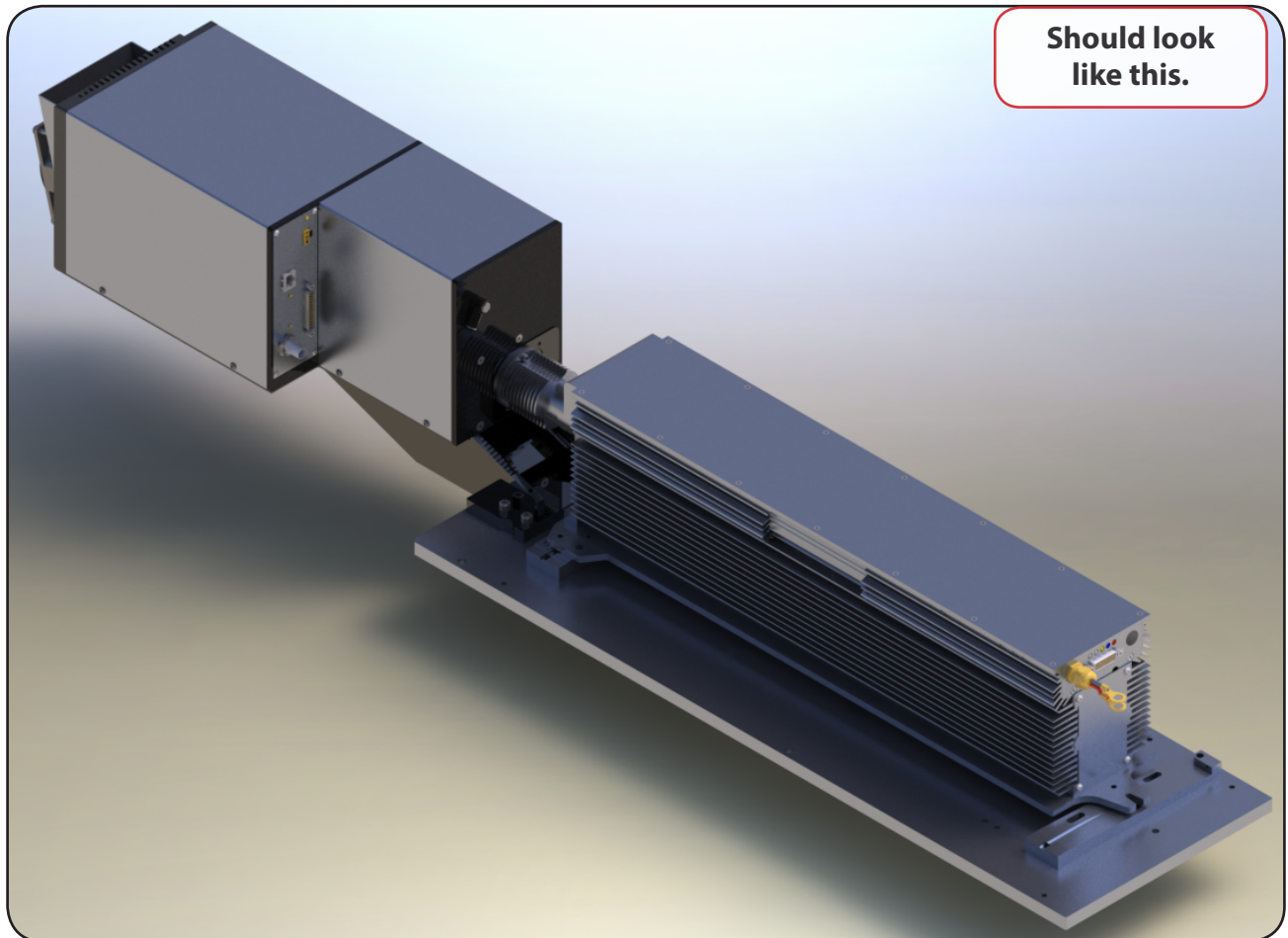

Firestar v Series air cooled laser & Flyer 3D System Quick Start Guide

SYNRAD

Electrical Connections:

14. Connect the Marking Head **DC power VDC** cable into the **Marking Head's power supply**.

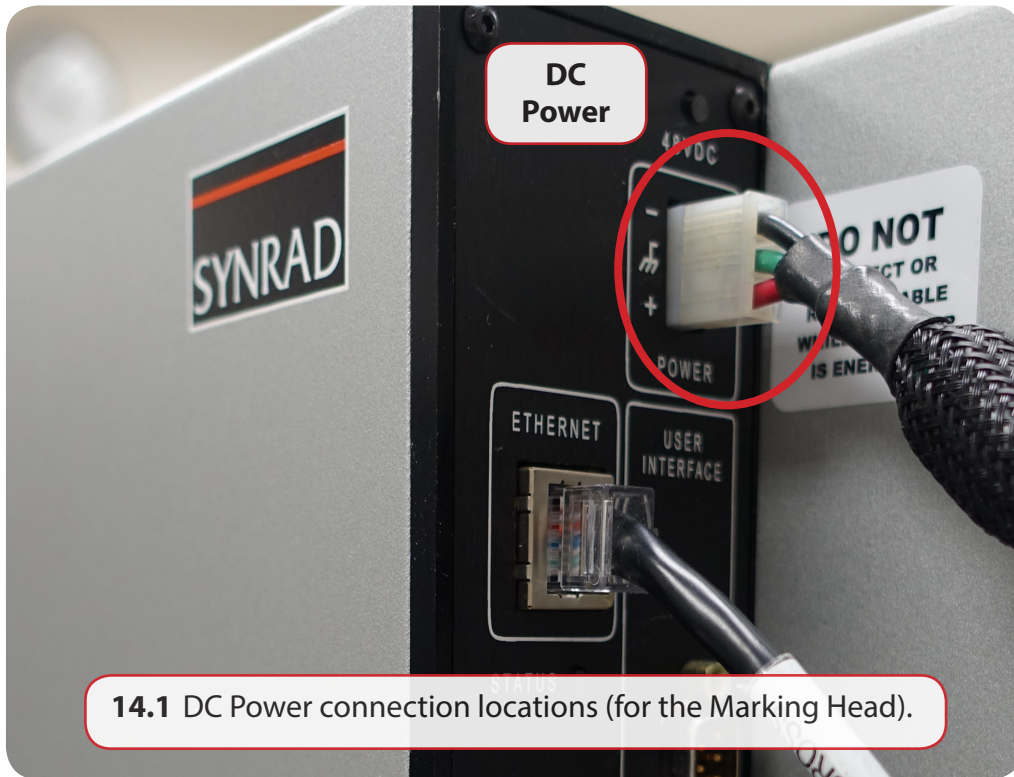

15. Connect the Laser **negative (black)** and the **positive (red)** DC power into the **laser's power supply**.

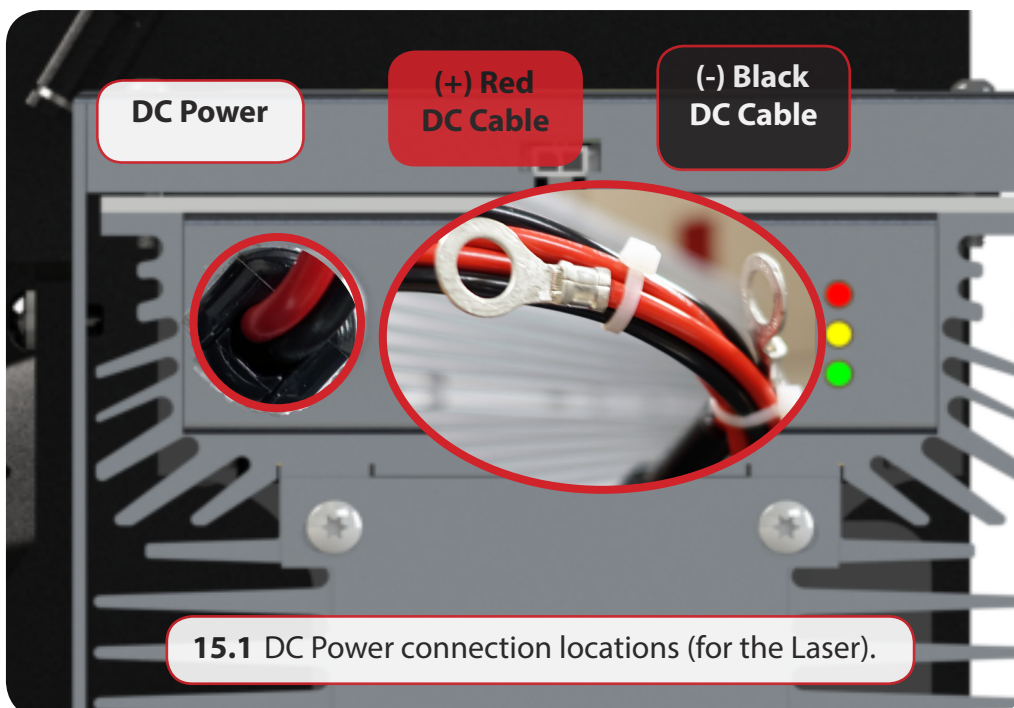

Firestar v Series air cooled laser & Flyer 3D System Quick Start Guide

SYNRAD

Control Connections:

Caution:



The **Quick Start Plug** bypasses the laser's safety interlock function, potentially exposing personnel to hazardous **invisible** laser radiation.

16. Connect the **laser's control BNC** interface to the laser.

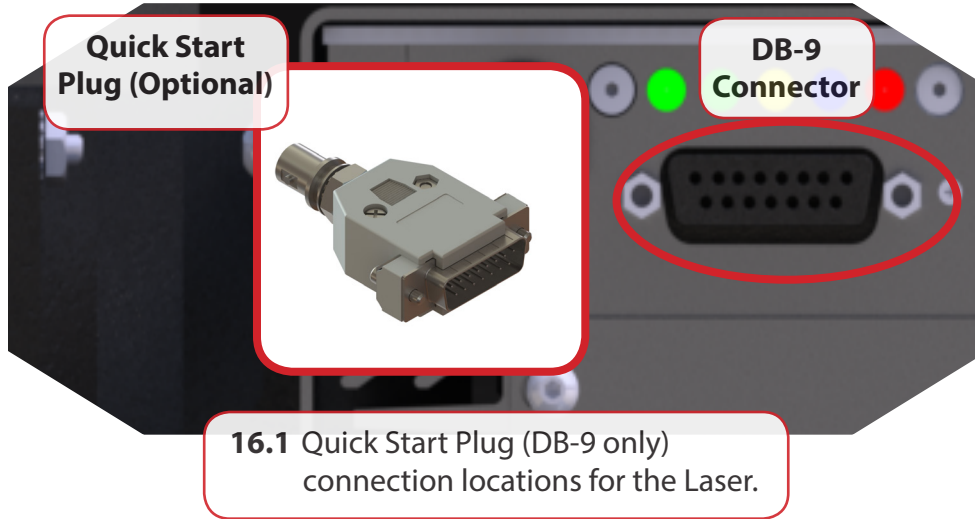

17. Connect the **Marking Head's Ethernet** (RJ-45) and **BNC** (laser control) interfaces. The ferrite bead, located at the end of the cable, should be connected to the Flyer 3D.



Firestar v Series air cooled laser & Flyer 3D System Quick Start Guide

SYNRAD

18. Mounting complete! The BNC connector is now ready to be connected to the laser. The Ethernet Connector is ready to be plugged into the PC's Ethernet port.

