

ti-Series™ Air/Fan Cooled Laser, FH Marking Head, kit & WMPv6

SYNRAD
A Synrad Company

Important Note:

- Read all ⚠️ Danger, ⚠️ Warning, ⚠️ Caution terms, symbols, and instructions located in the (Laser Safety Hazard information) sections in the ti-Series Laser Operation Manuals located on our website <http://www.synrad.com/synrad/docroot/resources/libraries/manuals>.

Laser and Marking Head Unpacking:

- Under your ti-Series laser at the bottom of the box you will find the **mounting hardware/components kit**. The **Marking Head hardware/components kit** is located in the top shipping **components box**. Don't forget to save all shipping containment including plug covers and set them aside.

1.1 Lifting the **ti-Series** laser correctly by holding in the middle, do not carry laser by the mounting feet, this can disturb alignment.

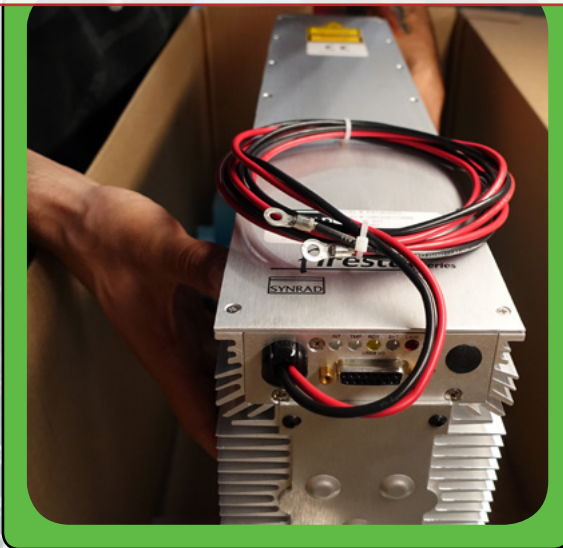

1.2 **Ti-Series laser** mounting/component kit for the laser and the **FH Flyer Marking Head** (Inset).



Important Note:



Keep All Foam and Packaging, you will need to re-use it when moving your laser to prevent damage that could void your warranty. Refer to this guide and the Technical Reference chapters in the laser's Operation Manual when re-packaging for shipping and/or relocation. Remove all accessory items not originally attached to the laser prior to re-packaging for shipping.

- Upon arrival, inspect all shipping containers for signs of damage. If you discover shipping damage, document the damage (photographically if possible), then immediately notify the shipping carrier (responsible party for any transportation damage) and SYNRAD®. See the inventory section within the Introduction chapter of the Operation Manual for packaging list(s).

Note: *If shipped completely assembled*, jump to the cooling section of this guide.



ti-Series™ Air/Fan Cooled Laser, FH Marking Head, kit & WMPv6

SYNRAD
a Heurle company

Lift both the both the marking head and the foam packaging out of the box.



Top Foam notch

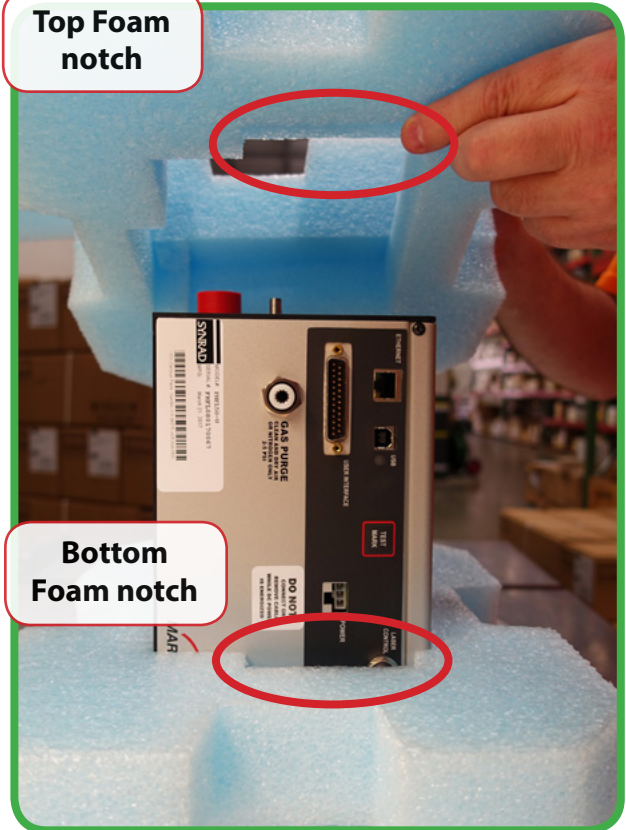

Bottom Foam notch

2.1 Place the unit with foam packaging on a firm surface, remove foam end cap, notice foam notch locations for ports and interfaces.

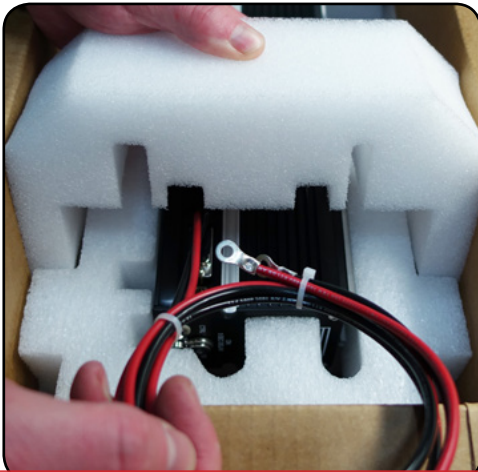

The wire harness can be damaged in shipping if not re-packaged as shipped!

Don't forget to remove the three (3) cap screws on the lens aperture cover if a focusing lens is ordered.



Important Note:



Caution! When packing the marking head for relocation or shipment, nothing can be on the sides of the unit at any time as damage will occur. All box components must be stowed as they were when they arrived.

Please refer to the examples above and the laser's Operation Manual drawings located at the end of the Technical Reference Chapter.

firestar series

Laser Unpacking:

3. **Unseat** the wiring by **sliding** the harness out of the notch, then down and out of the foam as shown above.

3.1. **Locate the wire harness in side one of the foam end caps.**



3.2. **Push the wire harness through the notch in the foam.**

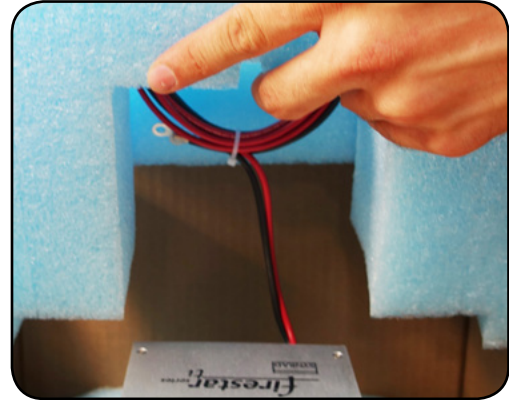

3.3. **Draper the wire harness across the top of the laser housing** when carrying by the base.



3.4. **Don't forget the hardware at the bottom of your box!**

4. **Locate the laser hardware kit** at the bottom of this box **under** the laser.

Important Note:



Caution! Unpacking the wire harness incorrectly can damage the laser.

Keep All Foam and Packaging, you will need to re-use it when moving your laser. Refer to this guide and the Getting Started/Technical Reference chapters in the laser's Operation Manual when re-packaging for shipping and/or relocation.

Caution! When packing the laser for relocation or shipment, nothing can be on the sides of the laser at any time as damage will occur. The skin on the sides of the laser is fragile! All box components must be stowed under the laser.

The wire harness will be damaged in shipping if not re-packaged as shown above.

ti-Series™ Air/Fan Cooled Laser, FH Marking Head, kit & WMPv6

SYNRAD
a firestar company

Mounting your Laser:

Note: ! Mounting feet and/or rails are optional, for complete details, refer to the ti-Series Operator's Manual. **Remove the laser aperture self-adhesive film before mounting to the rail.**

Don't tighten the path enclosure screws until the laser is mounted securely to the rail.

SYNRAD does not recommend mounting lasers in a vertical, (head and/or tail down) position. Please contact the factory for limitations as a vertical orientation increases the risk of damage to the lasers optics.

The laser's mounting feet are precisely aligned and shimmed at the factory to ensure alignment between the marking head and the Mounting Rail. Do not loosen or remove the mounting feet from the laser. See the FH Flyer Marking Head Operator's Manual for further details.

5. **Before** mounting the laser to the rail, ensure the **aperture seal is removed**.
6. Locate the **Mounting Hardware Kit** () path enclosure tube, marking head & laser hardware.

5.1 Remove the aperture seal.

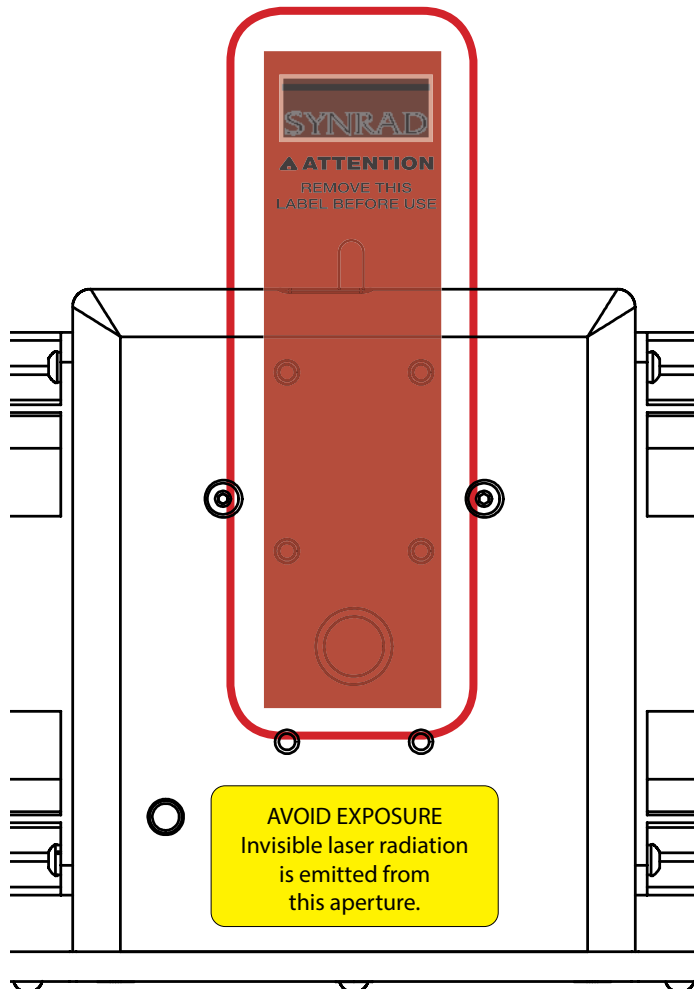

(Fan-Cooled ti60 Shown)

6.1 Path enclosure tube.

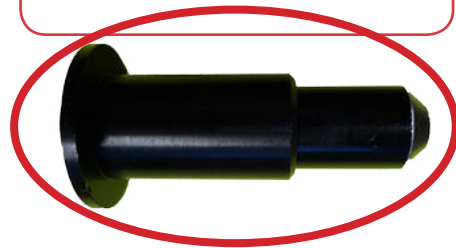

6.2 6-32 x 1" Laser Mounting socket head capscrews.



6.3 1/4-20 x 3/4" Marking Head Mounting socket head capscrews.



6.4 8-32 x 1/4" Marking Head Mounting button head socket screws.



6.5 Laser & Marking Head Mounting Kit(s).

ti-Series™ Air/Fan Cooled Laser, FH Marking Head, kit & WMPv6

SYNRAD
A Synova company

Mounting your Marking Head onto a Rail:

- Remove the **dust cover** & set aside, from the rear end of the **marking head**, unwrap the **mounting rail**, set it on a firm surface. Orient the rail so that the **L-bracket can be placed on the notch end of the rail**.
- Mount the **L-bracket** to the **rail** using the (4) 1/4-20 x 3/4" socket head capscrews as shown in the following figures.

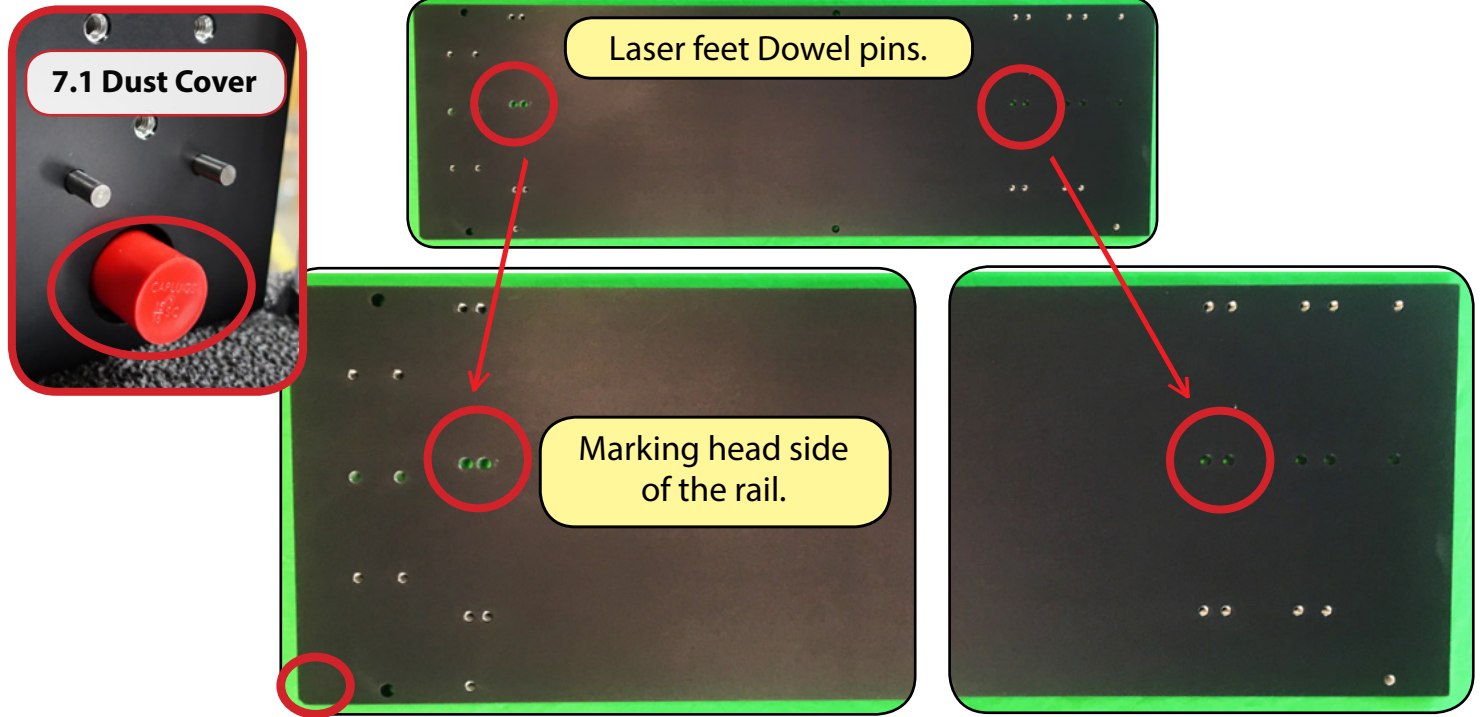

8.1 Notch end of the rail.

8.2 L-bracket mounting holes and notch locations on the rail.

8.3 Secure the L-bracket to the rail. (Four (4) 1/4-20 x 3/4").

Note: Assure the rail **notch** is on the **Marking Head** side of the rail.

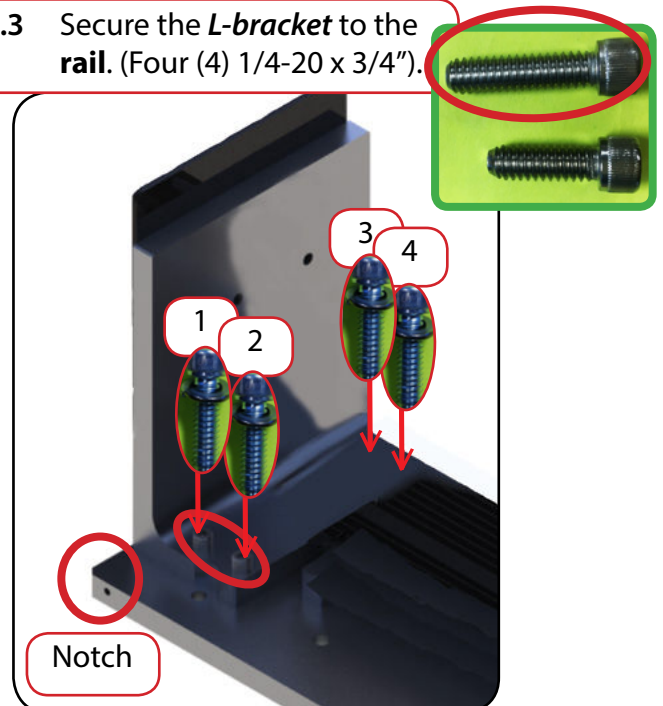
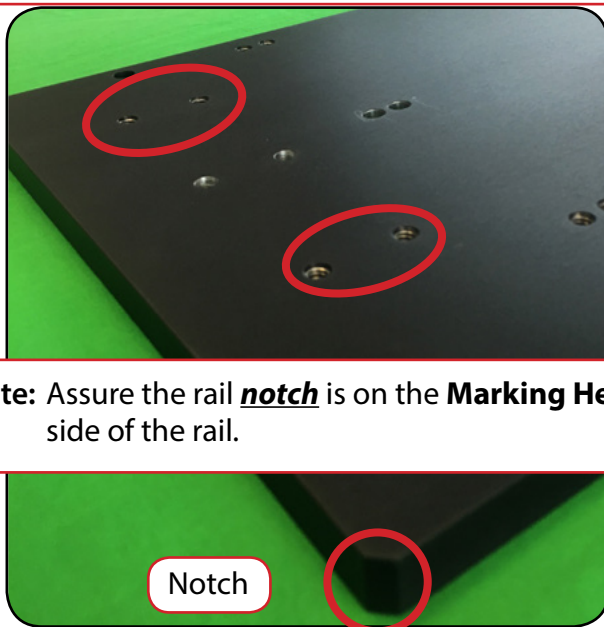

Mounting your Marking Head onto a Rail (Continued):

9. Place the **marking head** on the **L-bracket** as below. Assure the dowel pins protrude through the **L-bracket**. Install and tighten the three (3) 1/4-20 x 3/4" socket head capscrews.

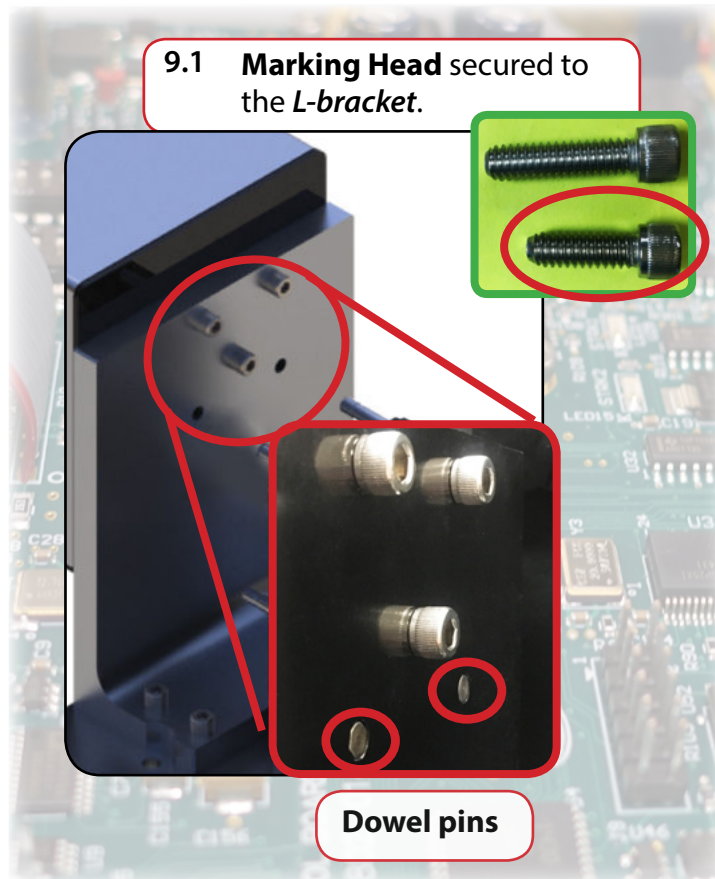

Important Check Point:



The anodized blanking plate & dust cover are removed from the Marking Head. The Marking Head is mounted adjacent to the notch on the rail. Refer to the appropriate chapter for more mounting details and the technical drawings in the ti-Series Operation Manual.

Mounting your Laser onto a Rail:

- Place the **laser** onto the **rail** with the front end facing the **marking head**. Ease the **laser** forward so the mounting feet holes align with their respective holes on the rail. Install/tighten four (4) M6 x 1 ISO or 1/4-20 UNC capscrews through the baseplate. Tighten to a maximum torque of 6.1 Nm (54 in lb.) See the figure below.

Note: Refer to the appropriate outline and mounting drawing for dimensions.

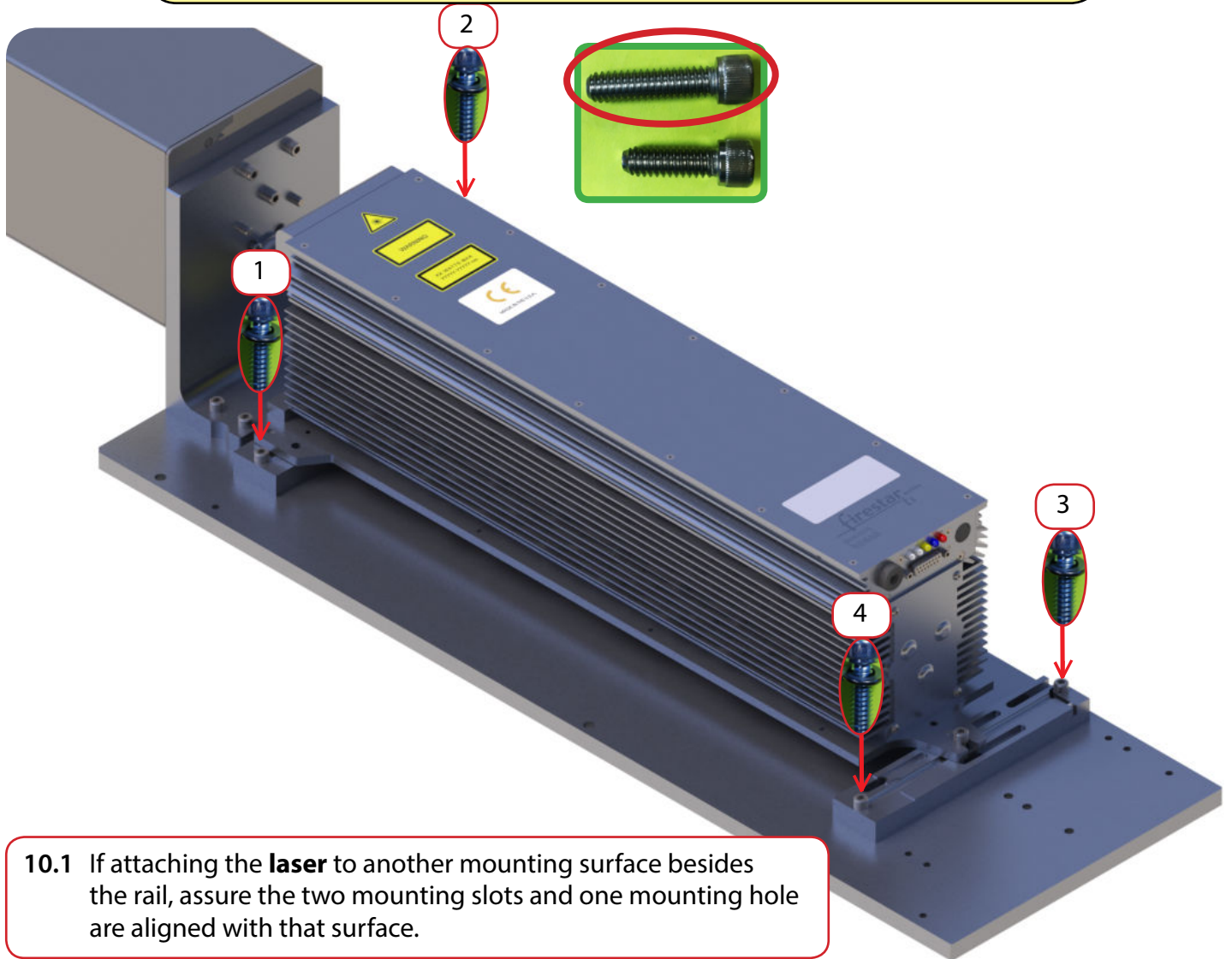

- 10.1 If attaching the **laser** to another mounting surface besides the rail, assure the two mounting slots and one mounting hole are aligned with that surface.

Important Note:



Calibration void if shim bolts are adjusted, if your laser has mounting feet as shown above, careful not to carry or handle the laser by the feet to minimize misalignment risk.

Mounting your Laser onto a Rail (Continued):

11. After both the laser and the marking head are mounted to the rail, assemble the spring-loaded path enclosure tube as shown below.

11.1 Compress the spring-loading path enclosure tube and place the larger end facing the marking head (on the I-bracket).

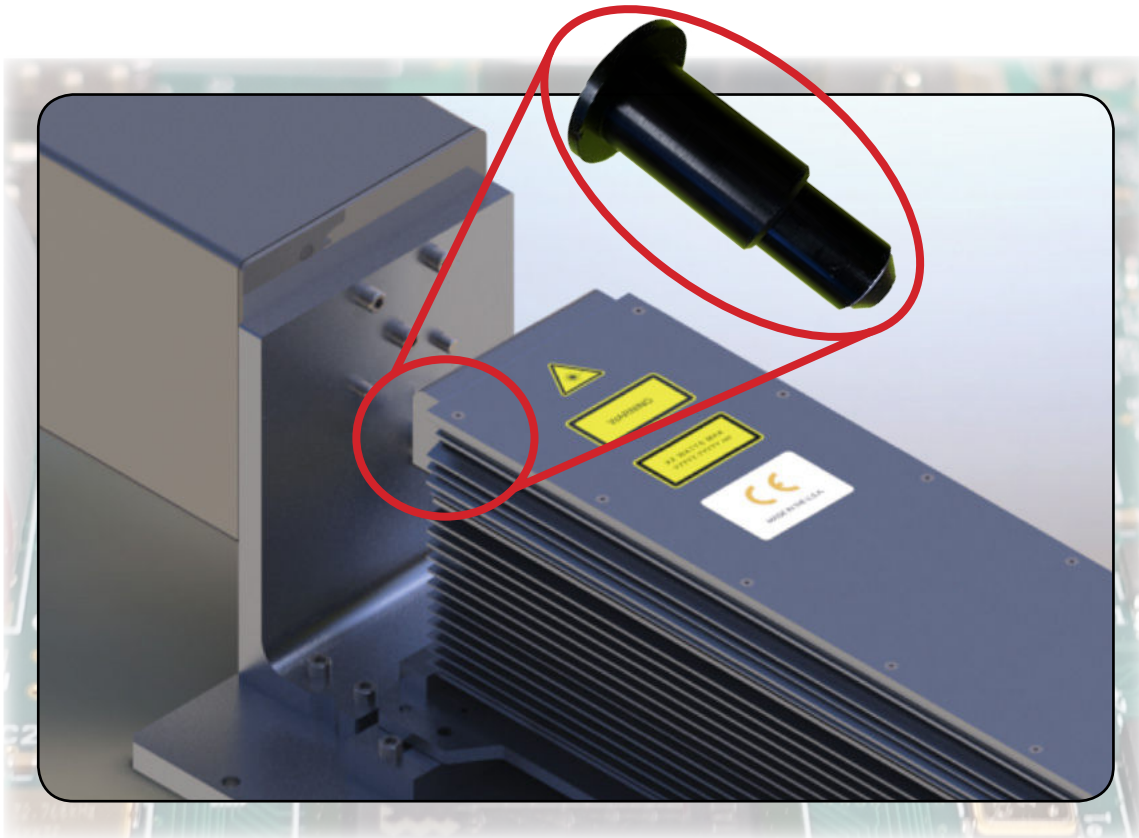

Important Note:



Consult the factory for further mounting angle guidance outside >20% from the horizontal. When mounting the laser, use only one metric or SAE fastener per mounting tab on the baseplate. Do not use any type of jackscrew arrangement as this will twist the baseplate and may distort the tube.

Note:



The recommended mounting orientation for the Ti-Series is horizontal. Refer to the drawings within the Ti-Series Operation Manual, see the Technical Reference chapter for further information.

Mounting your Laser onto a Rail (Continued):

12. Secure the path enclosure tube to the I-bracket with four (4) 8-32 x 1/4" button head socket screws as shown below.

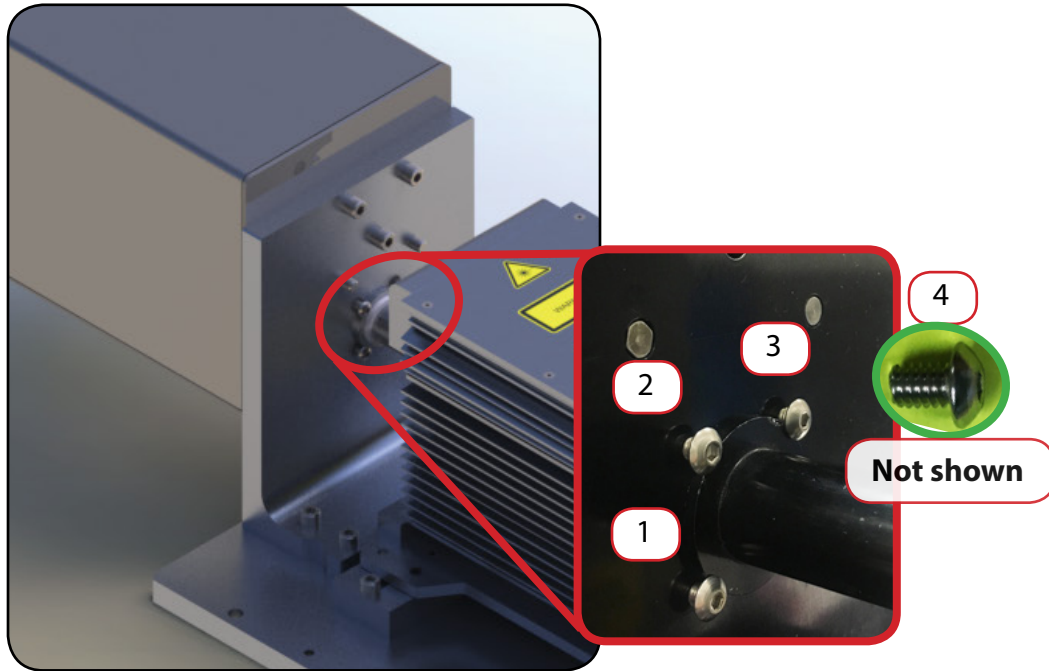

12.1 Assure the laser & marking head is securely mounted to the rail beforehand.

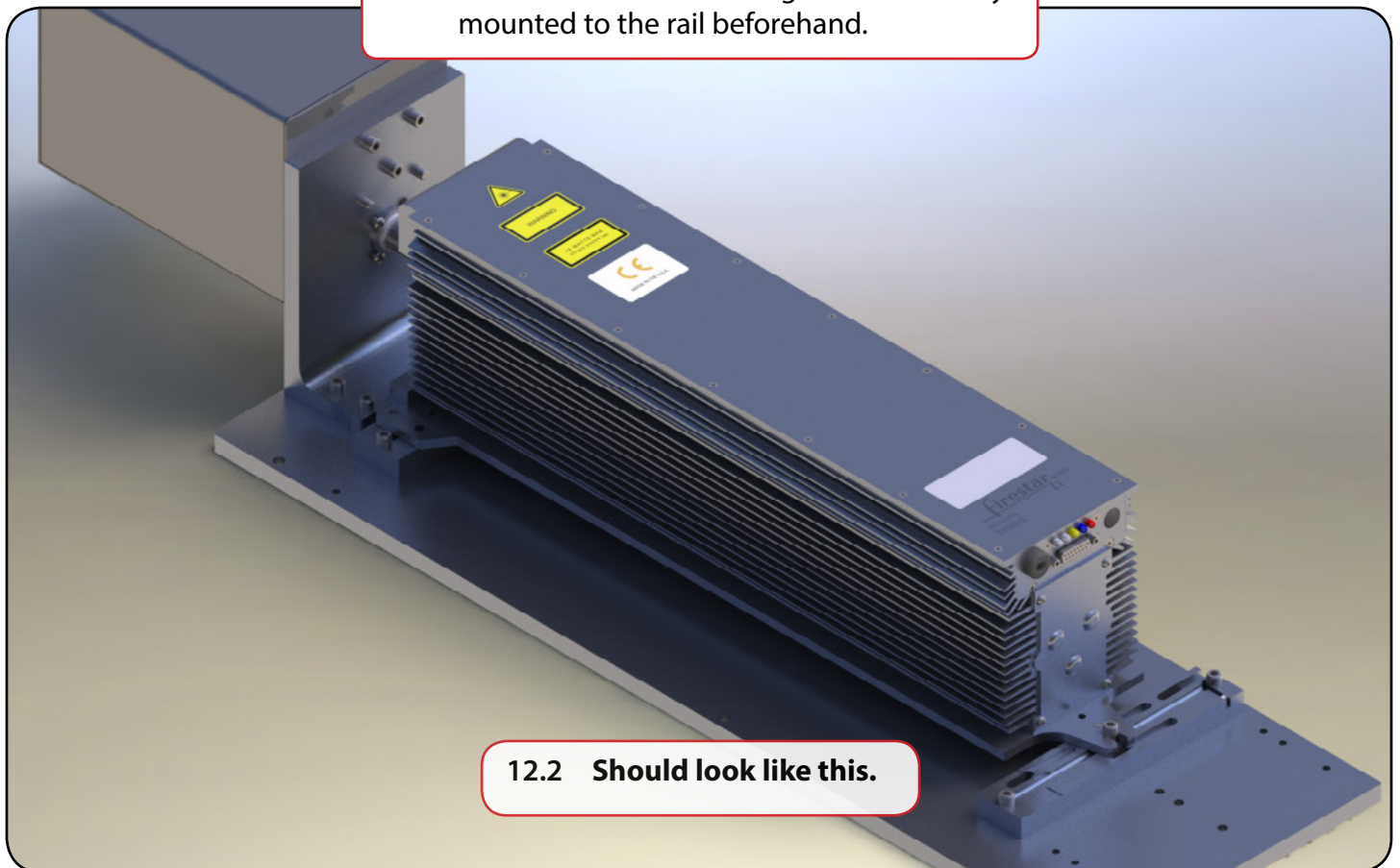

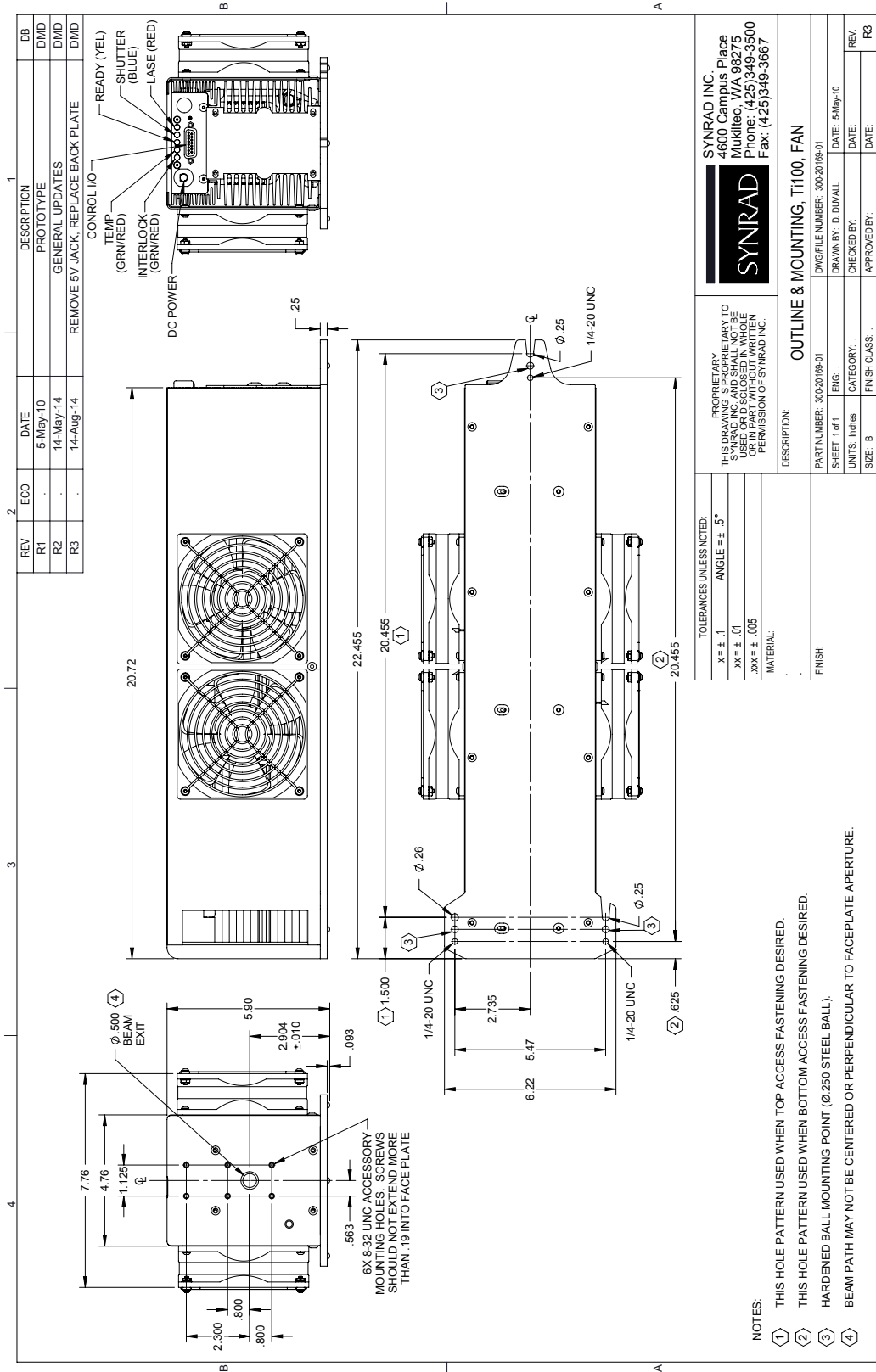

14.1 Mounting the two cooling fans so they are centered horizontally and vertically on each side of OEM ti100 laser.

Important
Note: Fans must have at a minimum 2.25" (52.7 mm) clearance between the unit and the wall or any obstructive surface.

14. If ti-Series water cooling is desired, please see the ti-Series water cooling Quick Start Guide located on our website.

ti-Series™ Air/Fan Cooled Laser, FH Marking Head, kit & WMPv6

SYNRAD
A Synrad Company

REV	ECO	DATE	DESCRIPTION	DB
A	4045	14-May-09	RELEASE TO PRODUCTION	DMD
B	4107	9-Sep-09	ADD NOTE 4	DMD
C	4118	28-Sep-09	ADD DIMS FOR FANS AND CUT-OUTS	DMD

FRONT VIEW: Dimensions include 7.72, 4.72, 5.63, 1.125, 2.300, .800, .800, 5.90, 2.905 ±.010, .094, 10.66, 20.83, 1.38, and a beam exit diameter of Ø .500 (4).

TOP VIEW: Dimensions include 22.455, 20.455, 1.500, 1/4-20 UNC, 2.735, 6.22, 5.47, 1/4-20 UNC, 20.465, and a hole diameter of Ø .250.

RIGHT SIDE VIEW: Dimensions include 20.455, 1/4-20 UNC, and a hole diameter of Ø .250.

Callouts: SHUTTER (BLUE), LASER (RED), READY (VCL), TEMP (GRN/RED), INTERLOCK (GRN/RED), DC POWER, CONTROL I/O, Ø 500 (4) BEAM EXIT, 5VDC ACCESSORY POWER, 6X 8-32 UNC ACCESSORY MOUNTING HOLES. SCREWS SHOULD NOT EXTEND MORE THAN .119 INTO FACE PLATE.

SYNRAD INC. Information:
 4600 Campus Place
 Mukilteo, WA 98275
 Phone: (425)349-3500
 Fax: (425)349-3667

PROPRIETARY TO SYNRAD INC. AND SHALL NOT BE USED OR DISCLOSED IN WHOLE OR IN PART WITHOUT THE PERMISSION OF SYNRAD INC.

TOLERANCES UNLESS NOTED:
 .x = ±.
 .xx = ±.
 .xxx = ±.
 MATERIAL:

DESCRIPTION: OUTLINE & MOUNTING, FAN-COOLED, T160/T180

FINISH:

PART NUMBER: 300-19847-02 **DWG/FILE NUMBER:** 300-19847-02

SHEET 1 of 1 ENG. **DRAWN BY:** D DUVALL **DATE:** 10-Mar-09

UNITS: inches **CATEGORY:**

SIZE: B **FINISH CLASS:**

CHECKED BY: **DATE:**

APPROVED BY: **DATE:**

NOTES:
 (1) THIS HOLE PATTERN USED WHEN TOP ACCESS FASTENING DESIRED.
 (2) THIS HOLE PATTERN USED WHEN BOTTOM ACCESS FASTENING DESIRED.
 (3) HARDENED BALL MOUNTING POINT (Ø .250 STEEL BALL).
 (4) BEAM PATH MAY NOT BE CENTERED OR PERPENDICULAR TO FACEPLATE APERTURE.

14.2 Mounting cooling fan so that it is centered horizontally and vertically on each side of OEM ti60/80 laser.

ti-Series™ Air/Fan Cooled Laser, FH Marking Head, kit & WMPv6

SYNRAD
a Firestar company

Power Connections:

Note: The negative (-) side of the DC input to the laser is internally connected so that the laser chassis serves as DC power ground.

You should isolate the laser's DC power supply so that the only grounded connection is at the laser. Alternatively, you can mount the laser chassis on an insulating pad or film in order to electrically isolate the laser when other equipment is grounded to the laser's DC power supply.

The FH Flyer head requires 30 VDC at 8A peak to operate. SYNRAD recommends the use of the DC-1 supply.

15. Verify that input AC power to the DC power supply is physically locked out or disconnected.
16. Connect the Marking Head **DC power VDC** cable into the **Marking Head's power** supply.

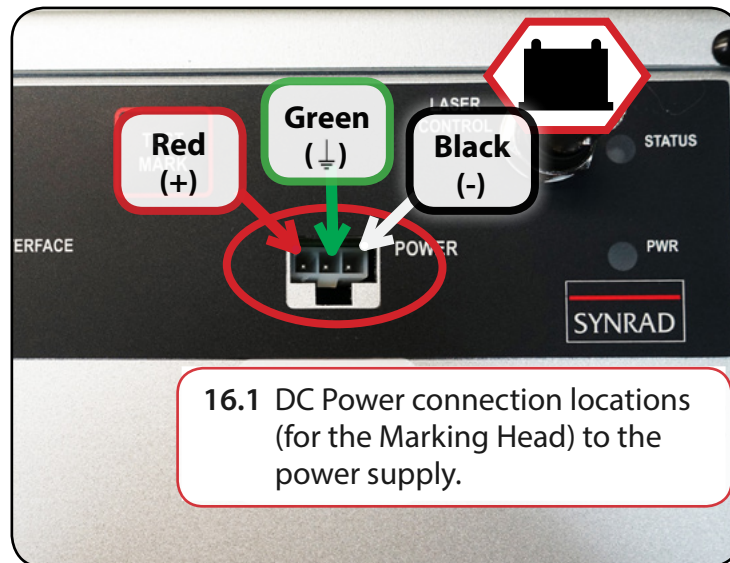

Power Connections (Continued):

Important

The ti-Series laser requires a DC power supply capable of providing 48 VDC at 18-35 A depending on model, refer to the specifications within the laser's operation manual.

Note:



For the ti-Series laser, SYNRAD® recommends the PS-48 DC power supply which provides a maximum of 50A at 48 VDC. AC input requirements for the PS-48 supply are 180-264 VAC, single phase (1Ø), 9.4 A max (@208 VAC), 47-63 Hz. Please refer to the corresponding power supply manual located on our website.

Do not reverse polarity when connecting the DC Power cable between the DC power supply and the ti-Series laser. Damage to the power supply may occur!

Because AC input connections and requirements vary from facility to facility, customers must provide the AC power cable or wiring.

Attach the red (+) wire(s) from the DC Power cable to the positive (+) 48 VDC output terminal and attach the black (-) wire(s) from the DC Power cable to the negative (-) 48 VDC output terminal.

15. Verify that input AC power to the DC power supply is physically locked out or disconnected.
16. Connect the Marking Head **DC power VDC** cable into the **Marking Head's power** supply.



17. Connect the negative (**black**) and the **positive (red)** DC power into the **laser's power** supply.
18. Connect one side of the 180–264V AC line to the input terminal labeled "AC/L".
19. Connect the other side of the AC line to the input terminal labeled "AC/N".
20. On the AC input section of the PS-48 power supply, connect the ground wire, typically green, to the input terminal labeled with the ground symbol.

Control Connections:

Important Note:



All control connections to Firestar ti-Series lasers are made through the 15-pin User I/O connector on the laser's rear panel. The User I/O port receives power commands from SYNRAD's UC-2000 Universal Laser Controller, or FH Flyer Marking Head, and also serves as the connection point for auxiliary signals between the laser and any parts handling, automation, or monitoring equipment.

Warning

Serious personal injury



Always use shielded cable when connecting your PWM Command signal source to PWM Positive/PWM Negative inputs.

In electrically-noisy environments, **long lengths of unshielded wire act like an antenna and may generate enough voltage to trigger un-commanded lasing.**

21. Connect the **laser's control BNC** interface to the **Marking Head's laser control port**.



Control Connections (Continued):

22. Connect the **other end of the BNC cable to the control input, 15 pin User I/O, via the Quick Start Plug QSP (Optional)** located on the rear end of the laser (Refer to the figure on the following page.)

22.1 Control connection locations
(for the Marking Head).

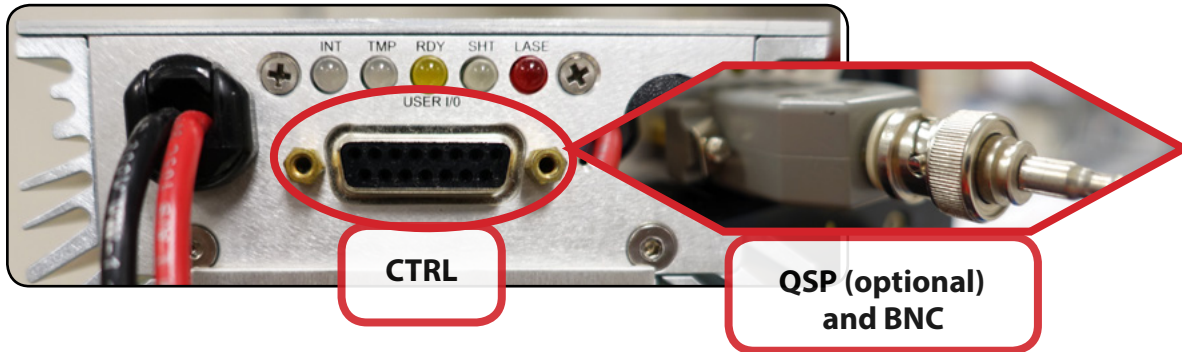

Caution:



The **Quick Start Plug** bypasses the laser's safety interlock function, potentially exposing personnel to hazardous **invisible** laser radiation.

23. The Ethernet connector is ready to be plugged into the PC's Ethernet port. Connect the crossover cable between your computer and the Flyer's Ethernet port.

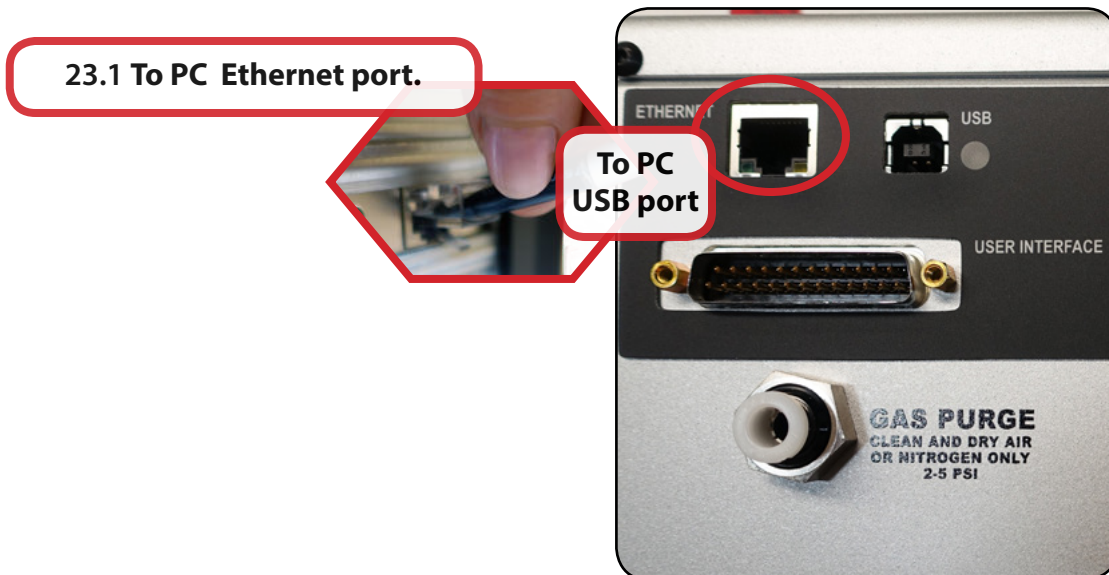

Note:

If using a customer-supplied DB-15 connector, wire it so that pin 9 (PWM Input) is connected to the Laser Control cable's center conductor and pin 1 (PWM Return) is connected to the Laser Control cable's shielded outer conductor.

ti-Series™ Air/Fan Cooled Laser, FH Marking Head, kit & WMPv6

SYNRAD
a Yoneda company

Control Connections (Continued):

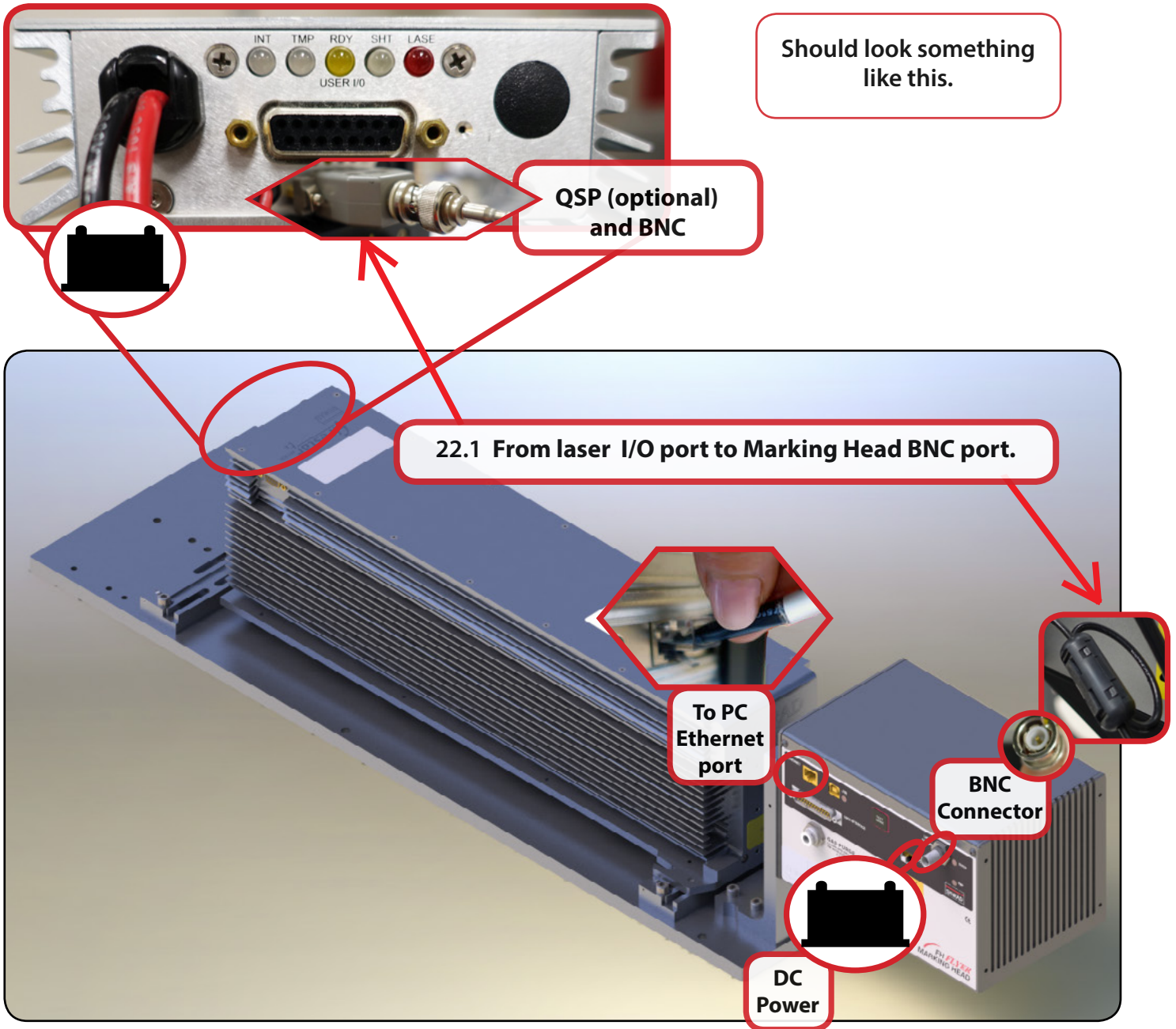

Control Connections (Continued):

Laser Markers are pre-configured at the factory to a fixed address of 192.168.100.100. This allows you to make a peer-to-peer Ethernet connection. Your computer's Ethernet settings are determined by your facility's computer network. The FH Flyer Marking Head requires a connection to a computer with a static IP address if not connected to a local network (Peer to Peer). Reference the FH Flyer Operation Manual located on our website for more information.

Set your computer's static IP address

24. Disconnect the computer from your local network.
25. Turn off Dynamic Host Configuration Protocol (DHCP), if enabled, and create a static IP address for your computer.

Note: The exact steps may vary depending on your operating system.

- a From the Start menu, go to Settings and choose Network Connections.
- b Double-click on the appropriate Local Area Network (LAN).
- c Locate the LAN's Internet Protocol (TCP/IP) properties.
- d Select "Use the following IP address:" and enter the following information:

IP Address: 192.168.100.101
Subnet Mask: 255.255.255.0
- e Click OK to submit the changes.

Laser Marking Software (WinMark®):

Important Note:



Prior to installation of the WinMark pro laser marking software on your computer, review the requirements in the WinMark pro Operation Manual, remove power or unplug the USB cable from the FH Flyer head to prevent windows from arbitrarily assigning a USB driver that is not compatible with Flyer's USB port protocols.

(WinMark®) v6 Software Installation:

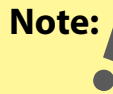

Note: Find the [WinMark pro v6 Software release notes](#) on our website. Refer to WinMark's website for supported operating systems and the [WinMark Pro Operation Manual](#).

26. Before upgrading to a newer version of WinMark pro, backup all existing .mkh mark files and uninstall prior version(s) of WinMark pro software.
27. Download the latest version 6 WinMark pro driver from our website. Exit all programs prior to Installation.
28. To install WinMark pro v6, and associated device drivers on a Windows® 7 or Windows® Vista™ operating system, right-click the **setup.exe** file and choose 'Run as Administrator...'

Important Note:



When upgrading from a v4 build to version v6, the WinMark Pro installer automatically performs a "clean install" because v6 uses a different subset of registry keys. The "Perform Clean Installation" and "Keep Current Program Settings" options are grayed out to indicate this installation is a "clean installation".

Upgrading from one v6 build to another does allow the option of preserving existing WinMark settings in the computer's System Registry. Choose Yes to preserve current WinMark Pro v6 registry settings including custom date code formats, object defaults, shift codes, auto startup info, and saved serial numbers. Choose No to erase all previous WinMark v6 Registry entries and perform a clean installation.

Note:



Due to Microsoft's implementation of registry virtualization, Windows Vista may require you to log on as an Administrator to perform certain functions like file importation or to save custom date code formats.

29. To install WinMark Pro v6, and associated device drivers, on a Windows® operating system, double-click the **setup.exe** file.
30. WinMark Pro v6 is a Microsoft .NET™ Framework-based application. If Microsoft .NET Framework Service Pack 1, or higher, is not installed on the computer, the installer will prompt you to click 'Accept' to install the .NET Framework. You must have the .NET Framework runtime and associated files installed to run WinMark Pro.

WinMarkpro v6 Installation (continued):

Note:  If WinMark Pro is un-installed, the .NET package is not removed, because these files may be used by other applications installed after the original WinMark installation.

31. When the .NET Framework installation is complete, reboot if prompted to do so. Otherwise the WinMark installer will continue.
32. If Microsoft C++ Redistributable x86 file runtime components are not installed on the computer, the installer will prompt you to click 'Install' to install C++ Redistributable files. You must have these files installed to run WinMark Pro.
33. Follow instructions in the installer dialog boxes to complete the WinMark Pro installation. You must click 'I Agree' to accept the WinMark Pro license agreement and continue the installation.

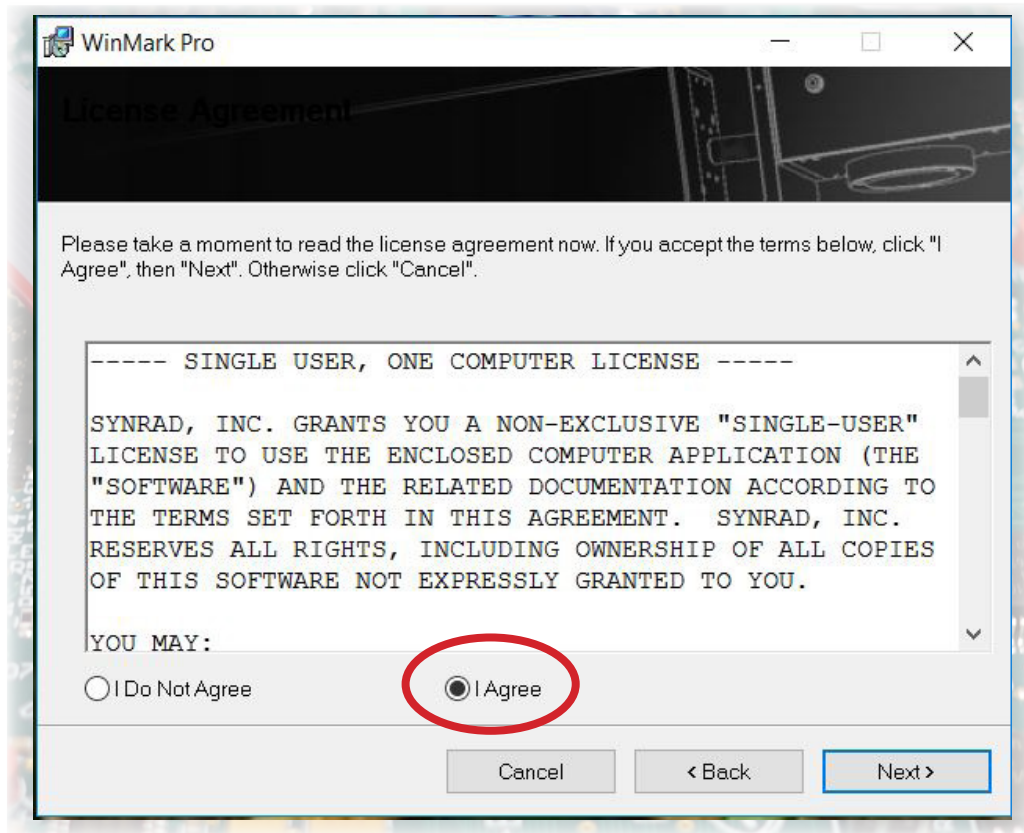

34. After installation is complete, remember to turn on any anti-virus software.

WinMark Launcher:

35. As part of the software installation, WinMark Launcher (Launcher.exe) is placed in the Program Files/ WinMark folder and a shortcut is placed on the desktop. Launcher allows non-administrative operators to load existing .mkh files for marking without opening WinMark's Drawing Editor by selecting the 'Open Drawing...' from the file menu.

35.1 Opening an existing *.mkh file.

36.1 Modifying an existing *.mkh file.

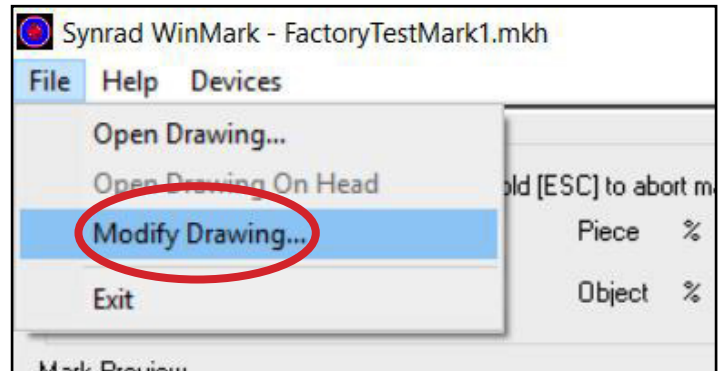
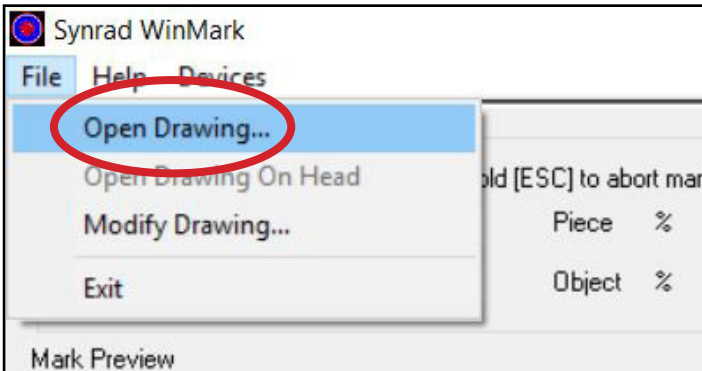

36. To add an Admin password so operators cannot modify a drawing select 'Modify Drawing...' which then opens the WinMarkpro application.

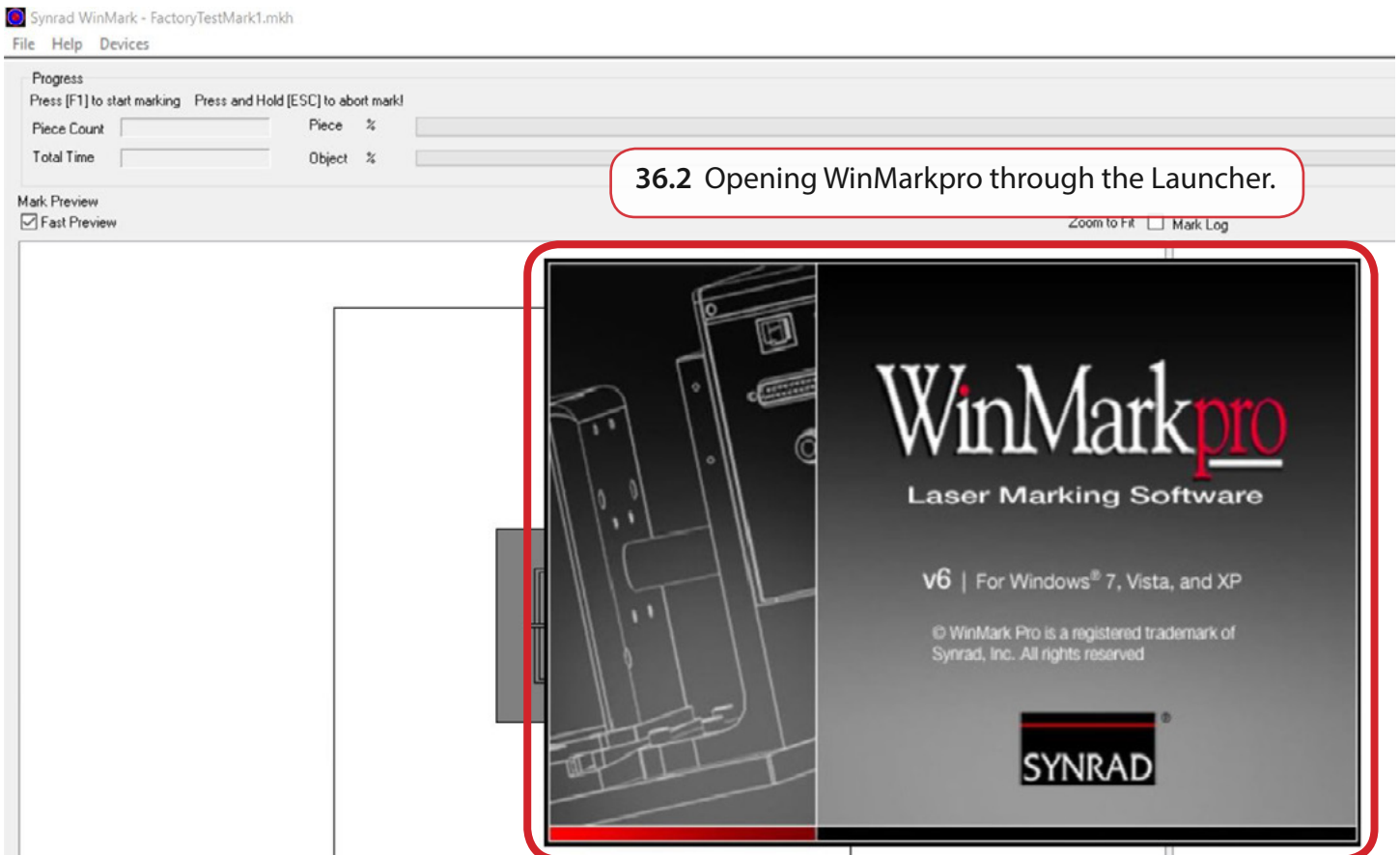

36.2 Opening WinMarkpro through the Launcher.

WinMark pro:

37. Once the WinMark Pro application opens, click the 'Tools' menu and select 'General Settings...'

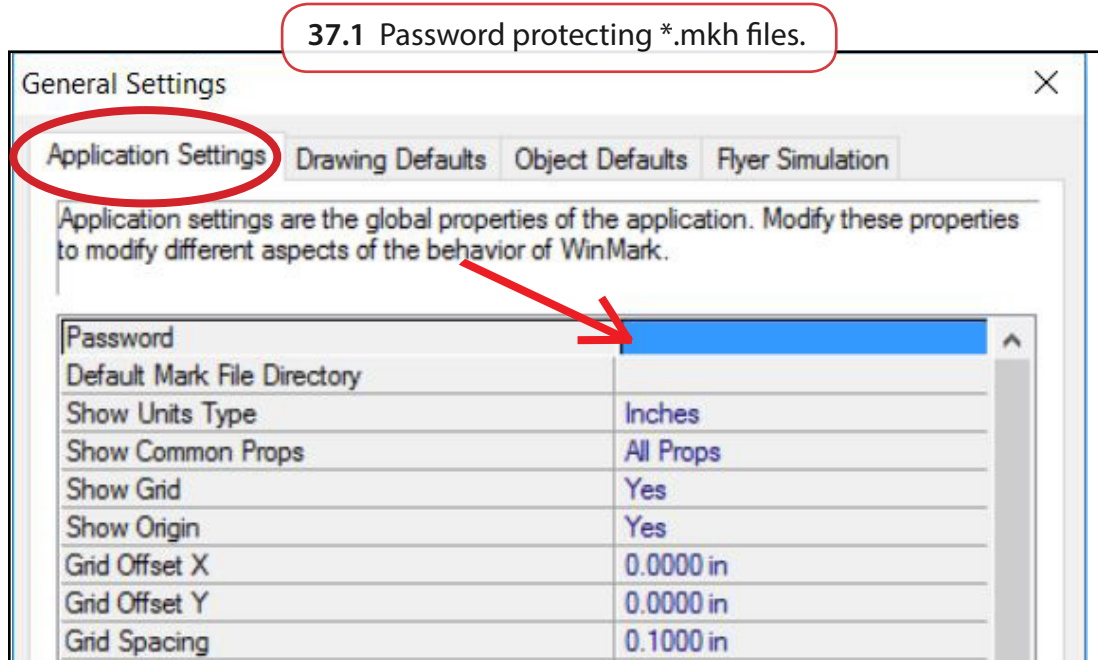

38. Using WinMark Pro's 'Startup Options...' within the Tools menu, Launcher can be configured to load a specific file and to start marking automatically when the computer is powered up.

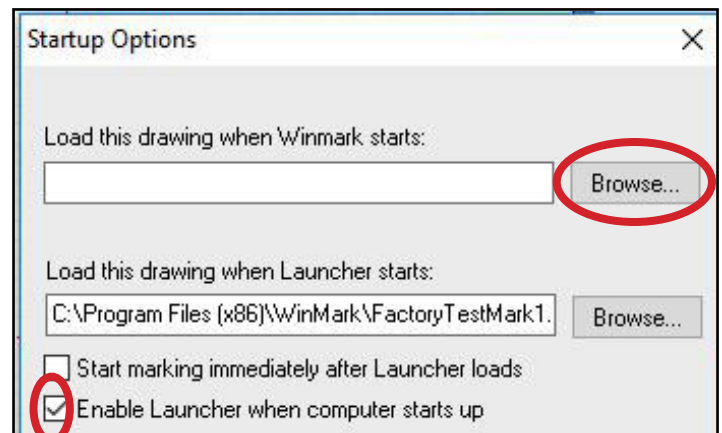
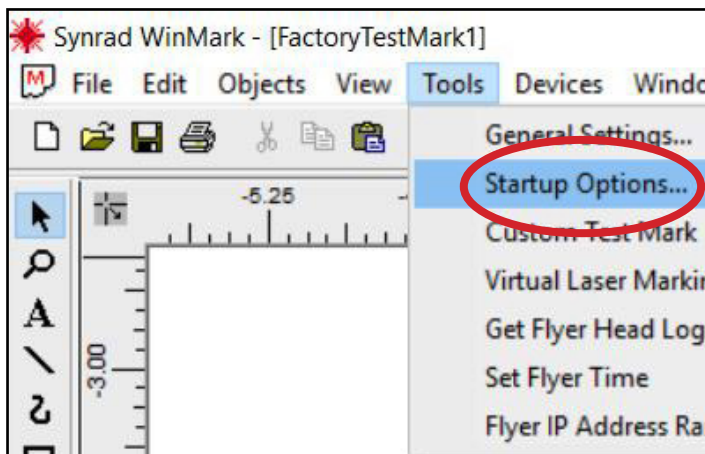

WinMark Digital Scope:

39. Digital Scope (**DigScope.exe**) is a stand-alone program included in the **WinMark** folder. Use Digital Scope to test individual inputs and outputs, turn the laser beam on or off, or adjust the laser's output power level. This "manual" control is especially useful when testing or troubleshooting I/O connections to/from the Flyer/Fenix Flyer marking head.

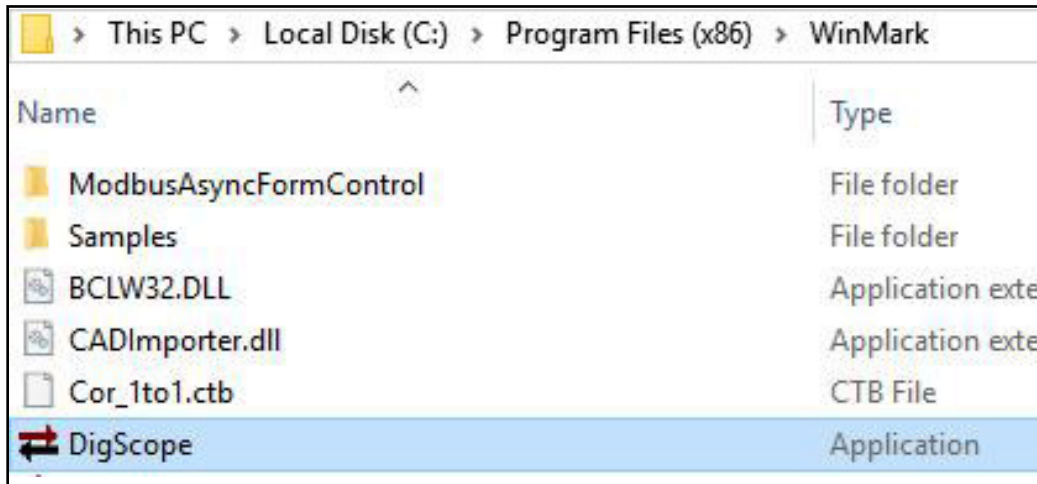

39.1 Digital Scope Application on the WinMark Pro Software CD.

40. The Samples folder is also placed in the WinMark folder during installation. This folder contains a sample communications DLL; Microsoft® Visual Basic®, Microsoft® Visual C++®, and Microsoft® C#® (in a .NET™ framework) sample code that demonstrates the use of WinMark's ActiveMark™ control methods; a folder of importable bitmap and vector graphics files; and sample mark files illustrating all of WinMark Pro's available stroke fonts.

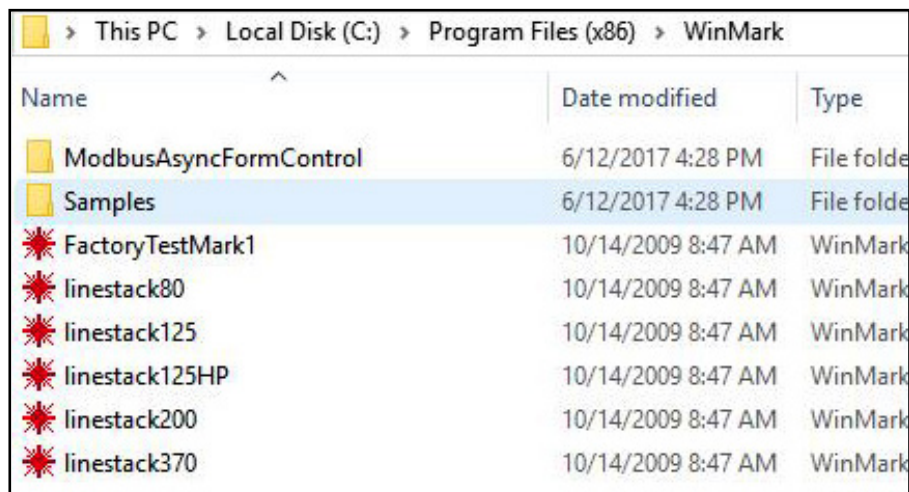

40.1 Samples folder on the WinMark Pro Software CD.

WinMark File Import Filters:

WinMark Pro automatically loads the File Import Filters during installation. These filters allow you to import a wide variety of graphic file formats. See the WinMark pro Operation Manual for details.

After the un-install is complete, some WinMark components, like .MKH mark files, will remain. To completely remove all WinMark-related files, go to C:\Program Files and delete the WinMark folder.

Uninstalling WinMark Pro:

If you decide to remove WinMark pro software from your computer, perform the following steps:

41. Click the **'Start'** button on the taskbar.
42. Select **'Programs'** and then locate the Synrad WinMark pro folder.
43. Click the **'Uninstall'** Synrad WinMark icon.
44. Follow the on-screen instructions.