

FIBER TIGER 3-AXIS SCAN HEAD

COMPACT 3-AXIS SCAN HEAD FOR PRECISE AND DYNAMIC LASER MATERIAL PROCESSING

Novanta develops photonics solutions through our globally recognized brands— ARGES, Cambridge Technology, Laser Quantum and Synrad— specializing in cutting-edge components and sub-systems for laser-based diagnostic, analytical, micromachining and fine material processing applications. Powerful lasers, coupled with advanced beam steering and intelligent sub-systems incorporating software and controls, deliver extreme precision and performance, tailored to our customers' demanding applications.

ROBOT-ASSISTED SCANNING

Engineered by ARGES, the Fiber Tiger is an extremely compact and robust scan head for robot-assisted laser processing and other 'on-the-fly' type applications in the mid to high kW range. This scan head features a highly dynamic Z-axis for ultrafast and precise 3-axis laser material processing. It has been designed especially for welding and cutting applications and can be employed in a wide variety of industrial sectors, like automotive, aerospace and machine construction. The Fiber Tiger is suitable for industrial-scale processing of all commonly used materials, such as metals, plastics and ceramics and can be operated with all commercially available singlemode or multi-mode fiber lasers.

Our innovative design offers additional scan head protection for harsh environments. The 'Crossjet' design ensures the long service life of the protective window and optics, even in harsh ambient conditions with intense sparking, while consuming only a very small quantity of compressed air.

Other optional features include options for high resolution vision systems and sensor port for pyrometry, plasma detection or OCT.



The Fiber Tiger is ideal in industries in: Aviation, Automotive, Additive Manufacturing, Production of Large Technical Goods, and Precision Mechanics.

TAILORED ENGINEERING CAPABILITIES

Through our highly specialized expertise and resources we can provide tailored solutions for your application needs. With a large selection of different laser sources, scan heads and handling systems to choose from, we can develop laser processes that are perfectly tailored to a wide variety of customer-specific products, components and materials.

- Laser-specific customization
- Sub-systems that include laser and beam path
- Customer-specific software extensions
- Laser process development
- Sample production

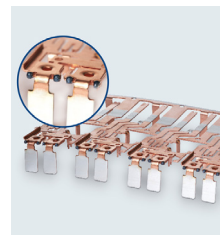

High precision welding of electronic components



Cutting of pre-painted chassis panels

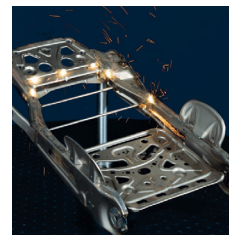

Welding of automotive components

FIBER TIGER

Specifications	275 mm	400 mm	600 mm
Working Distance	275 mm	400 mm	600 mm
Optical Scan Volume	240 x 240 x 70 mm ² /mm ³	314 x 314 x 125 mm ² /mm ³	478 x 478 x 200 mm ² /mm ³
Max Scan Speed	12,400 mm/s	16,000 mm/s	22,300 mm/s
Max Speed Z-Direction ²	7,000 mm/s	12,500 mm/s	20,000 mm/s
Repeatability	<0.5 μrad		
Zero Position Drift	<5 μrad/K		
Grain Drift	<15 ppm/K		
Max Scan Angle	0.79 rad		
Error of Orthogonality	<1.2 mrad		
Linearity	>99.9%		
Supply Voltage, DC	48 V		
Supply Voltage, Tolerance	+/- 1 V		
Max Standby Power Consumption	20 W		
Max Supply Input Current	8 A		
Operating Temperature Range	10°C ~ 40°C		
Storage Temperature Range	0°C ~ 50°C		
Non-Condensing Humidity	10% ~ 80%		
Cooling Water	Stainless steel cooling unit suitable for deionized water		
Pressure	3 bar ~ 5 bar		
Max Inlet Temperature Cooling	30°C		
Recommended Tube Material	Polyether Polyurethan		
Tube Diameter and Wall Thickness	Model Dependent		
Step Response 1%	0.72 ms		
Step Response 10%	1.96 ms		
Step Response 100%	14.52 ms		
Tracking Delay	0.4 ms		
Step Response Z-axis 1%	3 ms		
Step Response Z-axis 100%	12 ms		
Weight	7.8 kg		
Dimensions (L x W x H)	289 mm x 160 mm x 160 mm		

KEY SPECIFICATIONS INCLUDE:

- For all commercial single-mode and multi-mode fiber lasers
- For high-precision welding and cutting applications up to 8 kW
- Aperture 36 mm
- Fast Z-axis with acceleration of 800 m/s²
- Integrated beam expander
- Compatible with all ASC controllers and ARGES InScript® software
- Fiber coupling unit: QBH, Type D, clamp for collimated fiber output, Ø 30 or-- 35 mm, other types on request

References:

1. Under constant load and environment over 8 hours. 2. Preliminary data only.

FIBER TIGER

DIMENSIONS (MM)

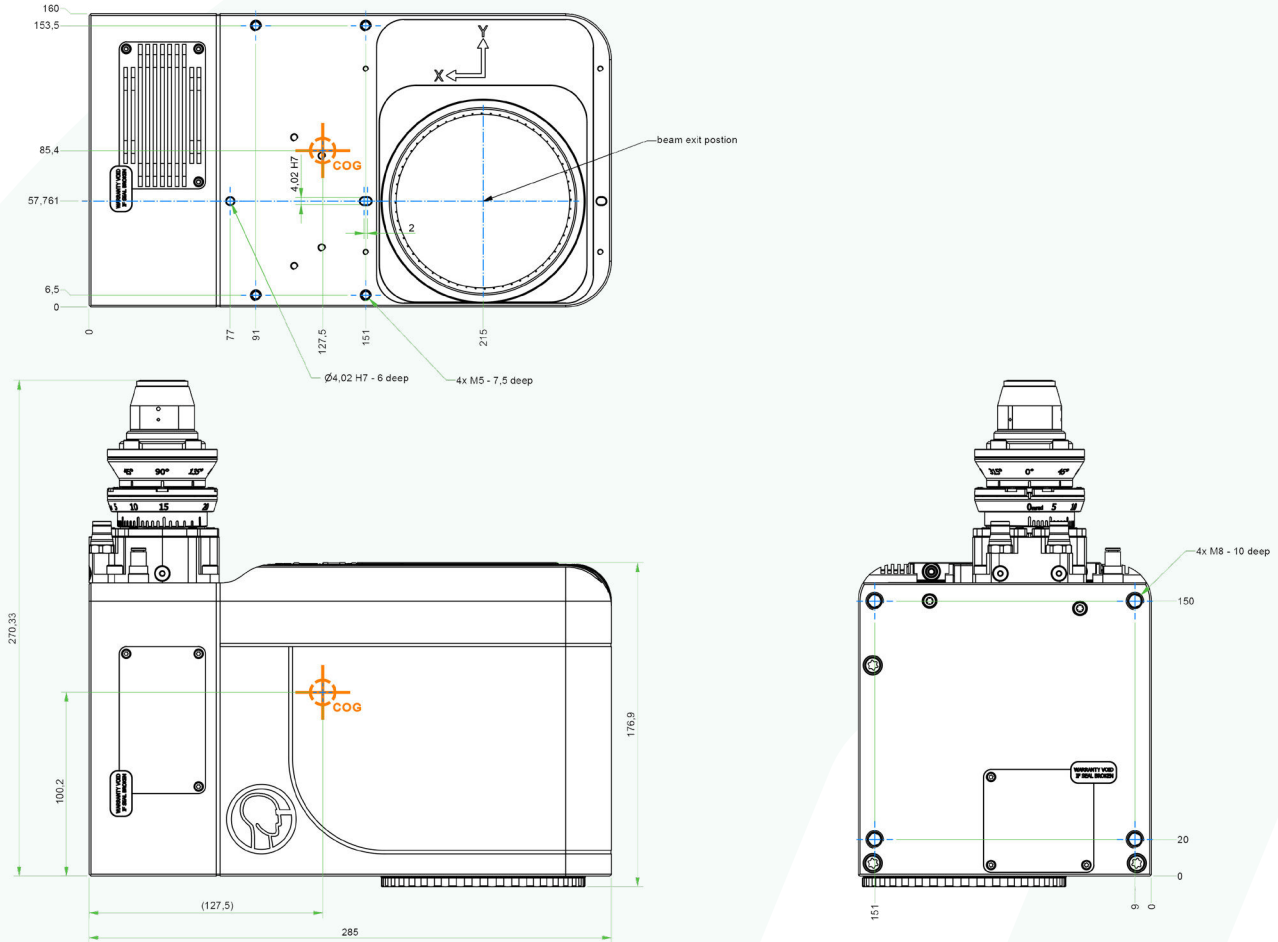

Notes:

All angles are in optical degrees, unless otherwise noted. Dimensions are in millimeters. All specifications are subject to change without notice.

CONTACT US

Americas, Asia Pacific

Novanta Headquarters
Bedford, USA
P +1-781-266-5700

Photonics@Novanta.com

Europe, Middle East, Africa

Novanta Europe GmbH
Wackersdorf, Germany
P +49 9431 7984-0

Milan, Italy
P +39-039-793-710

Photonics@Novanta.com

China

Novanta Sales & Service Office
Shenzhen, China
P +86-755-8280-5395

Suzhou, China
P +86-512-6283-7080

Photonics.China@Novanta.com

Japan

Novanta Service & Sales Office
Tokyo, Japan
P +81-3-5753-2460

Photonics.Japan@Novanta.com